



GAL[®] -to-MAC[®] Door Operator Conversion

Product instruction

Purpose

This product instruction provides a brief description of the features and components of GAL[®]-to-MAC[®] Door Operator conversion package. This product instruction also provides Field Personnel with information on installation procedures, operational checks and adjustments, and diagnostic procedures. Although this instruction provides information on primarily one type of GAL[®] door operator, the instructions can be applied to other GAL[®] door operators.

A604-001 (1/95)

© 1998, 1996 **MOLINE ACCESSORIES COMPANY**

This volume is not intended for distribution, and not approved for use as a source of information for any purpose or procedure. All rights reserved. No portion of this volume may be reproduced or used in any manner without written permission from Moline Accessories Company -- 107 18th Street; Moline, IL 61265



TABLE OF CONTENTS

Purpose	2
Safety	4
Description of PM/SSC door operator with Board 1Ø4™ & auxiliary locking board	5
Removing GAL® door operator components	6
Remove GAL® MOD style (side-opening)	6
Remove GAL® MOM & MOH styles (side-opening)	10
Remove GAL® MOD style (center-opening)	14
Remove GAL® MOM & MOH styles (center-opening)	18
Installing MAC® door operator	22
Install MAC® door operator (side-opening door)	22
Install MAC® door operator (center-opening doors)	24
Wire door operator	26
Wire gate switch	27
Wiring non-MIPROM logic controller	28
Adjusting door operator control Board 1Ø4™	30
Toggle switches	30
Measure current (optional)	31
Set potentiometers	31
Adjust door speeds	32
Adjust door closing force	34
Adjust nudge speed	35
Set microswitch cams	36
Adjust Board 1Ø4™ with auxiliary locking board	38
Replacement Parts	40



Safety

Participate in the successful installation of MAC[®] Car Door equipment— know the safety hazards related to any procedure, know what equipment is required, and know what tools and materials you should plan to have available beforehand.

- ▣▶ When working on the car canopy, be aware of tripping hazards.
- ▣▶ Use cords and power equipment protected by ground fault circuit interrupters.
- ▣▶ Make sure hoistways and work areas are adequately lighted.
- ▣▶ Make sure clearances exist in hoistway for equipment to be installed.

A604-002 (1/95)

Recommended tools & materials

Pre-arrange to have the following available.

- ✓ Small hand tools to fit assorted screws, bolts, and nuts
- ✓ Levels
- ✓ Drill with assorted bits
- ✓ Hex keys 5/64 inch - 13/64 inch
- ✓ Socket set 3/8 inch - 1-1/4 inch in 1/16" increments
- ✓ Open or box wrenches 3/8 inch - 1 inch in 1/16 inch increments
- ✓ Tape measure
- ✓ Tap and Die set
- ✓ Vise-grip pliers

A604-S11 (1/95)

Description of PM/SSC door operator with Board 1Ø4™ & auxiliary locking board

GAL®-to-MAC® door operators are shipped with the Board 1Ø4™ and auxiliary locking board kit preinstalled and preadjusted, requiring only final adjustment. Auxiliary locking boards cannot be used with earlier versions of Board 1Ø4™.

The Board 1Ø4™ with auxiliary locking board has all performance and adjustment properties of the Board 1Ø4™, and features the additional ability to provide door holding functions required by some elevator codes. To keep adjustments simple, Board 1Ø4™ adjustments are the same with or without the auxiliary locking board. An additional adjustment is necessary for setting door locking current. An indicator lamp on the auxiliary board makes this adjustment a fast and simple process requiring no extra tools.

The PM/SSC is a standard performance door operator, most commonly used, with a speed of 1FPS to 2 FPS (average 1.5 FPS, peak 2.5 FPS). The PM/SSC door operator with Board 1Ø4™ has the following operations and features:

- Door control power
- Current control
- Speed & travel limits
- Acceleration & deceleration
- Diagnostics & switch adjusting
- Auxiliary piloting

Door control power. PM/SSC door operator control uses a low voltage permanent magnet DC motor. The DC motor is powered by pulse width modulated power (high speed switching - 20,000 hz). The motor responds to average voltage of high frequency pulses, and not individual pulses.

Current control. PM/SSC door operator control has a current sensing circuit in both open and closed directions to supply feedback to the speed control circuit. This current sensing circuit regulates closing door force, and open/stall current caused by a hooked interlock. The current sensing circuit also guarantees that PM/SSC door operator control relay contacts do not break or make when motor armature current is present—helping to prevent damage to relay contacts. Motor direction is controlled by reversing the armature connection using a conventional relay system.

Speed & travel limits. PM/SSC door operator control selects speed and travel limits with cam operated microswitches. These microswitches operate relays tied into the speed direction circuits.

Acceleration & deceleration. PM/SSC door operator control has an internal soft-start circuit which regulates smooth acceleration and deceleration. Soft-start circuit allows average motor voltage to change gradually when speeds change.

Diagnostics & adjusting switches. PM/SSC door operator control has two small toggle switches mounted on the common circuit board. The TEST/RUN switch and O-OFF-C switch are used to:

- Signal door opening or closing from the car top during diagnostics and adjusting
- Disconnect the door open and close signals
- De-activate the internal shutdown timer

Auxiliary piloting. The PM/SSC door operator control also has a Form “C” Open and a Form “C” Closed relay contact for auxiliary piloting.

A604-003 (1/95)



Removing GAL[®] door operator components

There are several styles of GAL[®] door operators that can be replaced with the GAL[®]-to-MAC[®] door operator. The GAL[®] styles described in this manual are MOD, MOM, and MOH. All three styles are used for both side-opening and center-opening cab doors. The procedure for removing the MOM and MOH door operators is the same, but the procedure for removing the MOD door operator is different.

The following sections describe procedures for removing the GAL[®] door operator components.

- Remove GAL[®] MOD style (side-opening door)
- Remove GAL[®] MOM & MOH styles (side-opening door)
- Remove GAL[®] MOD style (center-opening doors)
- Remove GAL[®] MOM & MOH styles (center-opening doors)

Some GAL[®] door operators have a drive arm support (1) on the baseplate and others do not. Use the following procedures for removing a GAL[®] door operator with a drive arm support. If the GAL[®] door operator does not have a drive arm support, you can also use the following procedures, or remove the GAL[®] door operator and baseplate as a unit.

A604-004 (1/95)

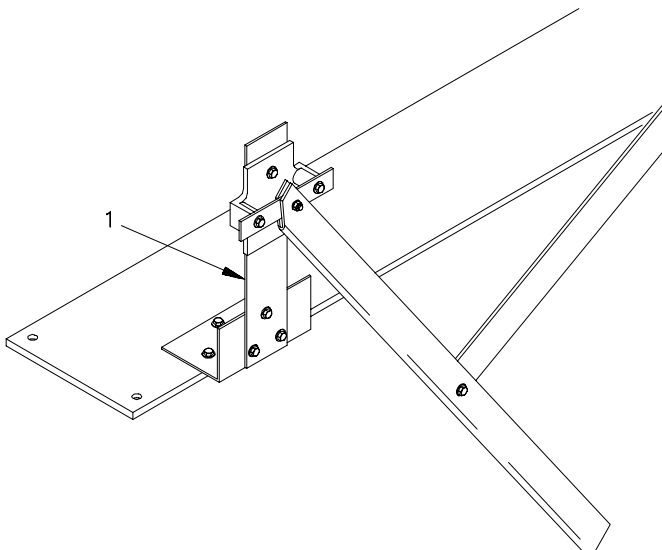

Z604-014(1/95)

REMOVE GAL[®] MOD STYLE (SIDE-OPENING)

When the GAL[®] door operator has a drive arm support, there are several dimensions to record before removing any components. These recorded dimensions make it easier to install the MAC[®] door operator. Use the following procedures to record the critical measurements and remove the GAL[®] components.

Recording Critical measurements - MOD style (side-opening)

1. Turn off electrical power to the door operator.
2. Measure the diameter of drive sheave (1) from top to bottom. Divide diameter by two and measure down that distance to crank arm (2). Mark that point on crank arm (2) and label it "A".
3. Measure the distance "B", from center of pivot point (3) to point "A" on crank arm (2). Record dimension "B" for use when installing the MAC[®] door operator.
4. Open the car doors until the pivot point (3) and the crank arm (2) are parallel to the edge of the baseplate (6). Measure the distance "C" between the back of the crank arm (2) and the edge of the baseplate (6). Record dimension "C" for use when installing the MAC[®] door operator.

A604-005 (1/95)

Record GAL door operator measurements

sheave dia. divided by 2	"B"	"C"	Car

Z604-T01 (11/94)

Door Operator Conversion

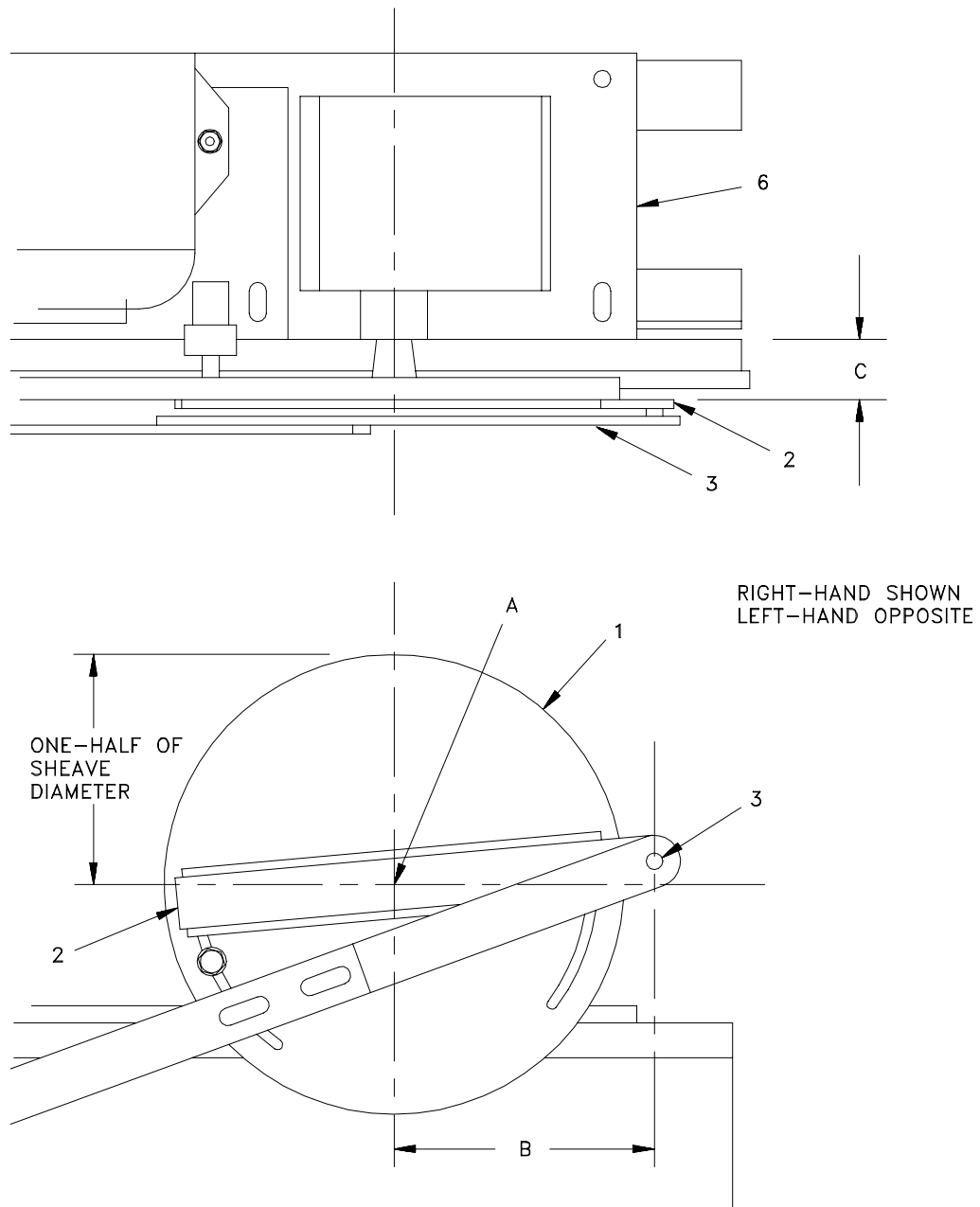

Z604-005(1/95)

MOD style (side-opening)



Removing components MOD style (side-opening)

If GAL[®] door operator has a drive arm support, ensure that all critical dimensions are recorded before removing any components.

For more information on critical dimensions, refer to section titled: Recording Critical Dimensions - MOD style (side-opening).

1. Turn off electrical power to the door operator.
2. Remove two bolts and nuts (1) and crank arm (2) from drive sheave (3). Save bolts and nuts (1) and crank arm (2) for use when installing MAC[®] door operator.
3. Tag and disconnect the gate switch wiring before removing flexible conduit (4) from control box (5). Tag and disconnect the door operator control wiring from the car junction box.
4. Remove four bolts from bearing block (6) and two bolts from adjusting bolt bracket (7).
5. Remove chain (8) and belt (9) from intermediate sheave (10).
6. Remove bearing block (6), intermediate sheave (10), belt (9), and adjusting bolt bracket (7) from baseplate (11).
7. Remove hardware from motor mounting guide stud (12) and four bolts from motor mount assembly (13).
8. Remove motor (14) and motor mount assembly (13) from baseplate (11).
9. Use Vise grip pliers to remove the motor mounting guide stud (12) from baseplate (11).
10. Remove wingnut (15) and cover from control box (5).
11. Remove two bolts, control box (5), and mounting plate (16) from baseplate (11).
12. Remove four bolts from bearing block (17). Remove bearing block (17), chain (8) and drive sheave (3) from baseplate (11).
13. Remove two bolts and stop roller bracket (18) from baseplate (11).
14. After removing the MOD style components, drive arm support (19) is the only part on baseplate (11).

A604-006 (1/95)

Door Operator Conversion

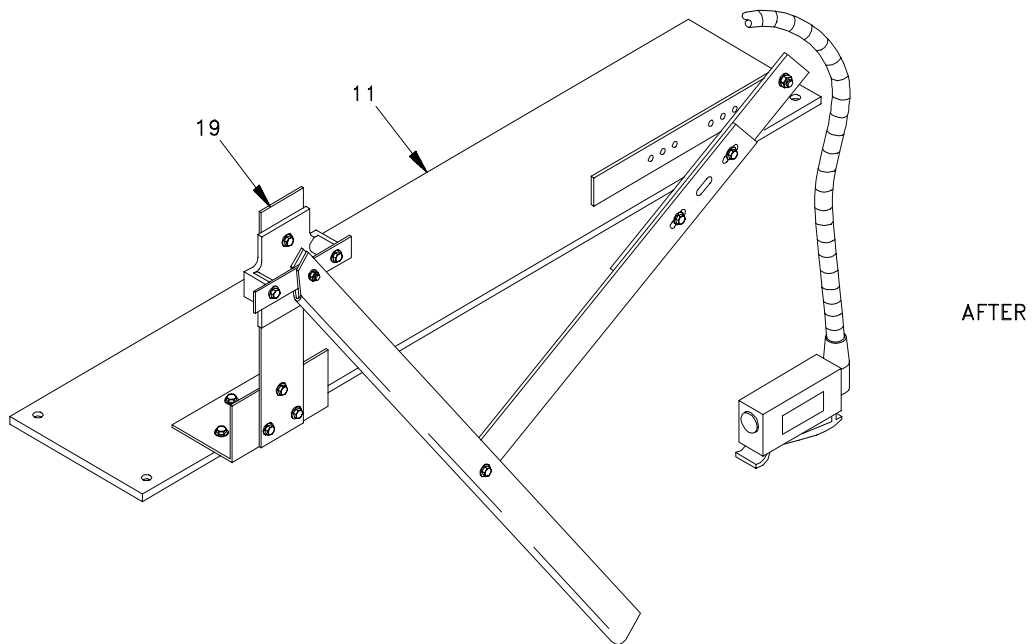
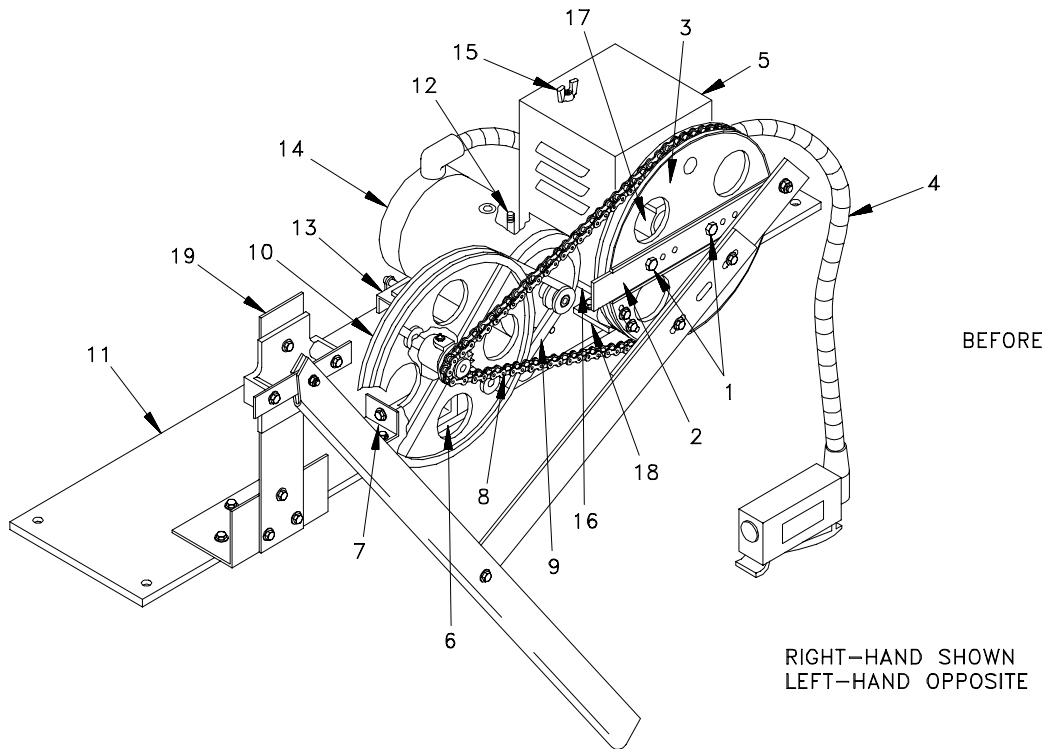

Z604-001(1/95)

MOD style (side-opening)



REMOVE GAL[®] MOM & MOH STYLES (SIDE-OPENING)

When the GAL[®] door operator has a drive arm support (1), there are several dimensions to record before removing any components. These recorded dimensions make it easier to install the MAC[®] door operator. Use the following procedures to record the critical measurements and remove the GAL[®] components.

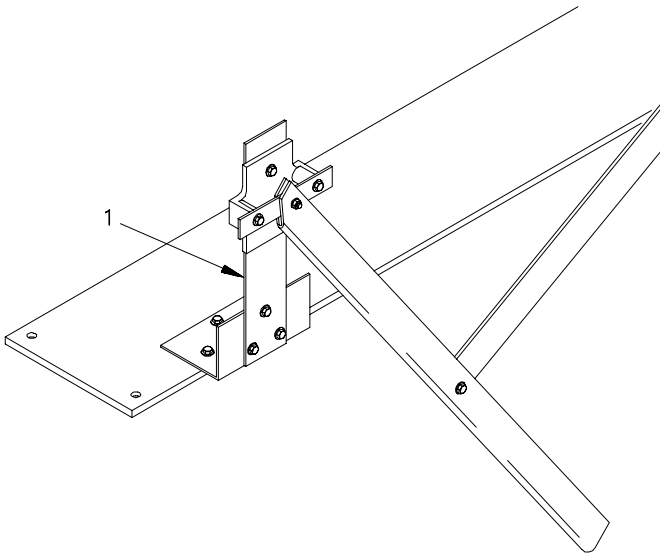

Z604-014(1/95)

Recording critical measurements - MOM & MOH styles (side-opening)

1. Turn off electrical power to the door operator.
2. Measure the diameter of drive sheave (1) from top to bottom. Divide diameter by two and measure down that distance to crank arm (2). Mark that point on crank arm (2), and label it "A".
3. Measure the distance "B", from center of pivot point (3) to point "A" on crank arm (2). Record dimension "B" for use when installing the MAC[®] door operator.
4. Open the car doors until the pivot point (3) and the crank arm (2) are parallel to the edge of the baseplate (6). Measure the distance "C" between the back of the crank arm (2) and the edge of the baseplate (6). Record dimension "C" for use when installing the MAC[®] door operator.

A604-007 (1/95)

Record GAL door operator measurements

sheave dia. divided by 2	"B"	"C"	Car

Z604-T01 (11/94)

Door Operator Conversion

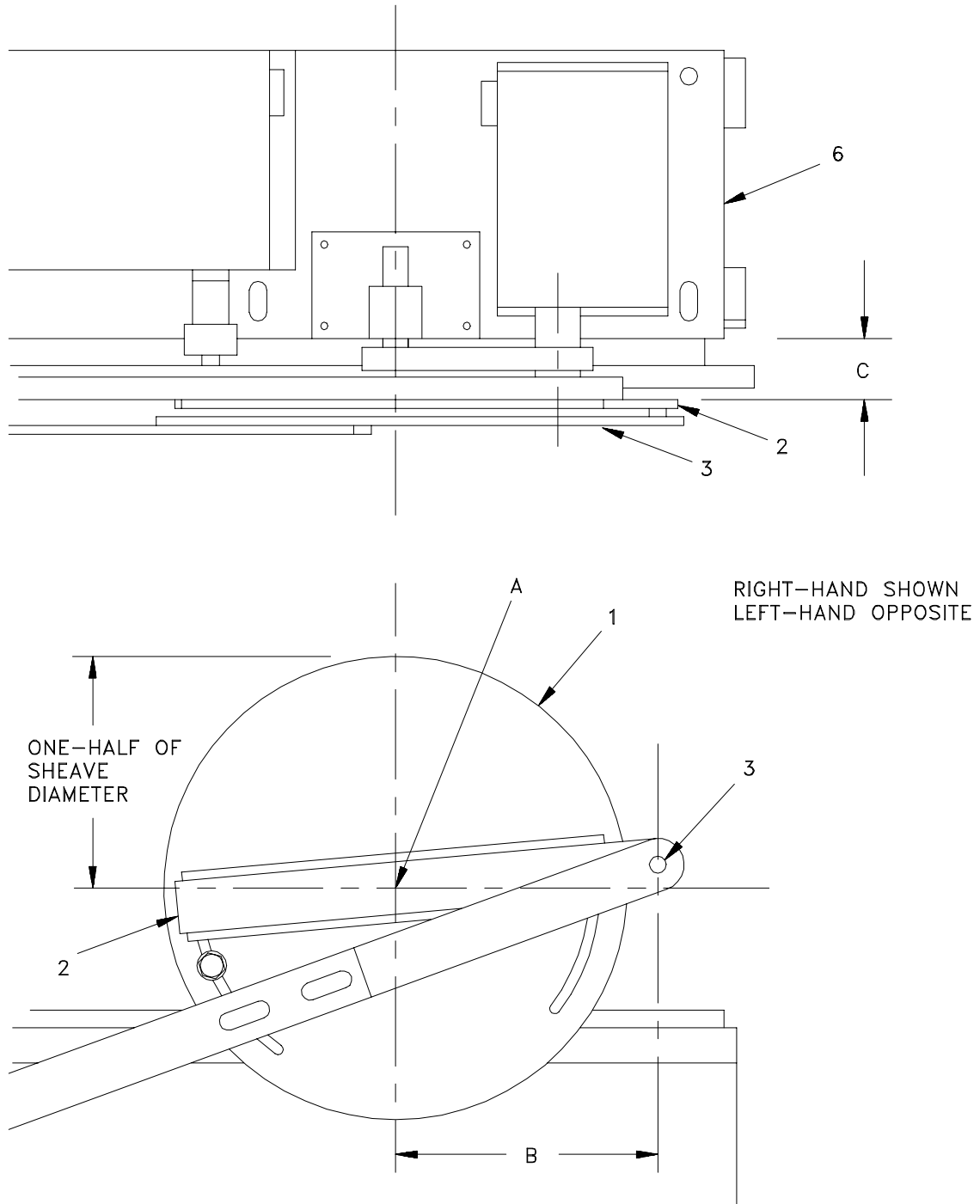

Z604-006(1/95)

MOM & MOH styles (side-opening)



Removing components MOM & MOH styles (side-opening)

If GAL[®] door operator has a drive arm support, ensure that all critical dimensions are recorded before removing any components.

For more information on critical dimensions, refer to section titled: *Recording Critical Dimensions - MOM & MOH styles (side-opening)*.

1. Turn off electrical power to the door operator.
2. Remove two bolts and nuts (1) and crank arm (2) from drive sheave (3). Save bolts and nuts (1) and crank arm (2) for use when installing MAC[®] door operator.
3. Tag and disconnect the gate switch wiring before removing flexible conduit (4) from control box (5). Tag and disconnect the door operator control wiring from the car junction box.
4. Remove four bolts from bearing block (6) and two bolts from adjusting bolt bracket (7).
5. Remove chain (8) and belt (9) from intermediate sheave (10).
6. Remove bearing block (6), intermediate sheave (10) and adjusting bolt bracket (7) from baseplate (11).
7. Remove hardware from motor mounting guide stud (12) and four bolts from motor mount assembly (13).
8. Remove motor (14) and motor mount assembly (13) from baseplate (11).
9. Use Vise grip pliers to remove the motor mounting guide stud (12) from baseplate (11).
10. Remove four bolts and control box (5) from baseplate (11).
11. Remove four bolts and terminal box (15) from baseplate (11).
12. Remove four bolts from bearing block (16). Remove chains (8 & 17), bearing block (16) and drive sheave (3) from baseplate (11).
13. Remove two bolts and stop roller bracket (18) from baseplate (11).
14. After removing the MOM & MOH style components, drive arm support (19) is the only part on baseplate (11).

A604-008 (1/95)

Door Operator Conversion

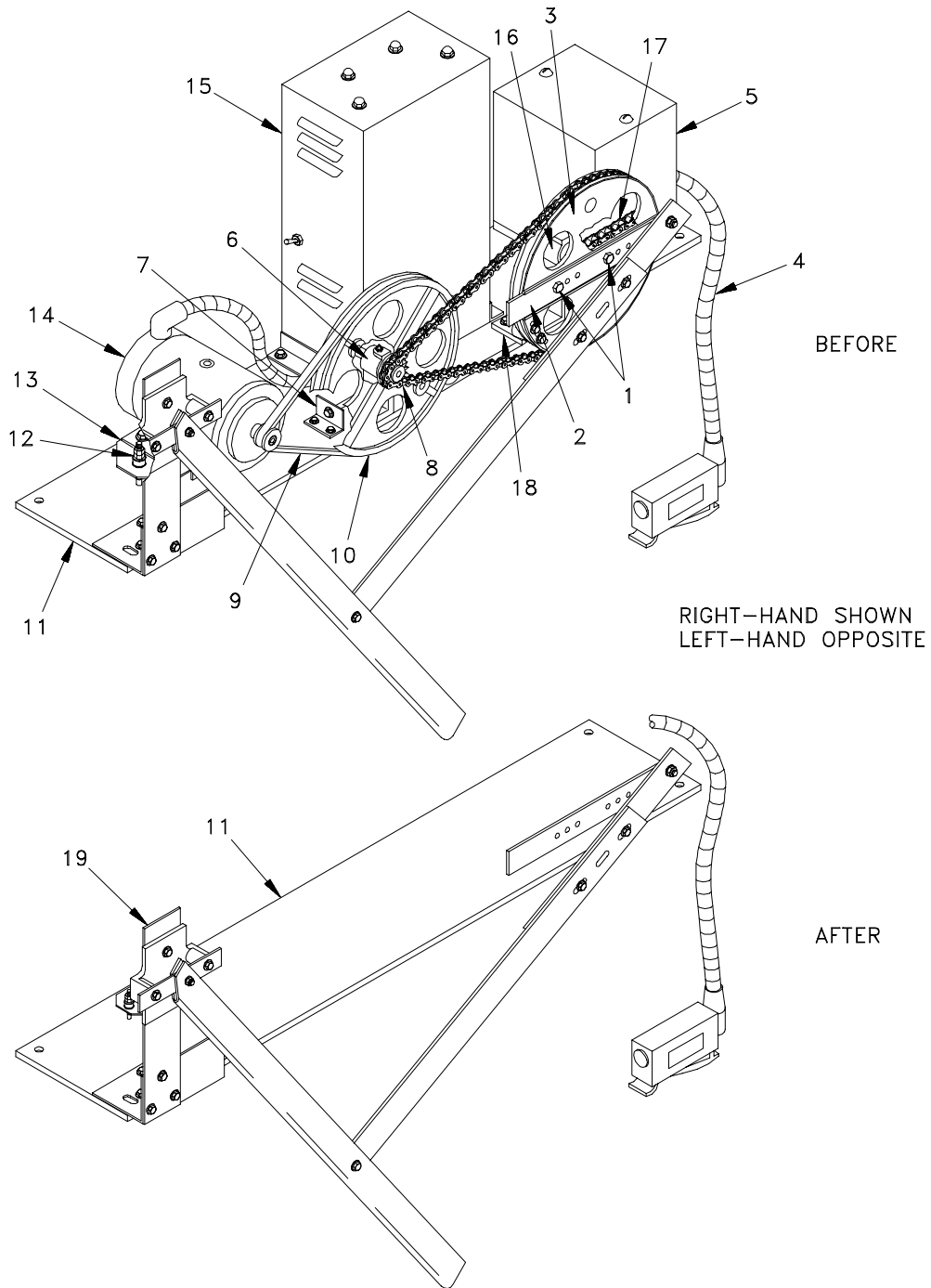

Z604-002(1/95)

MOM & MOH styles (side-opening)



Door Operator Conversion

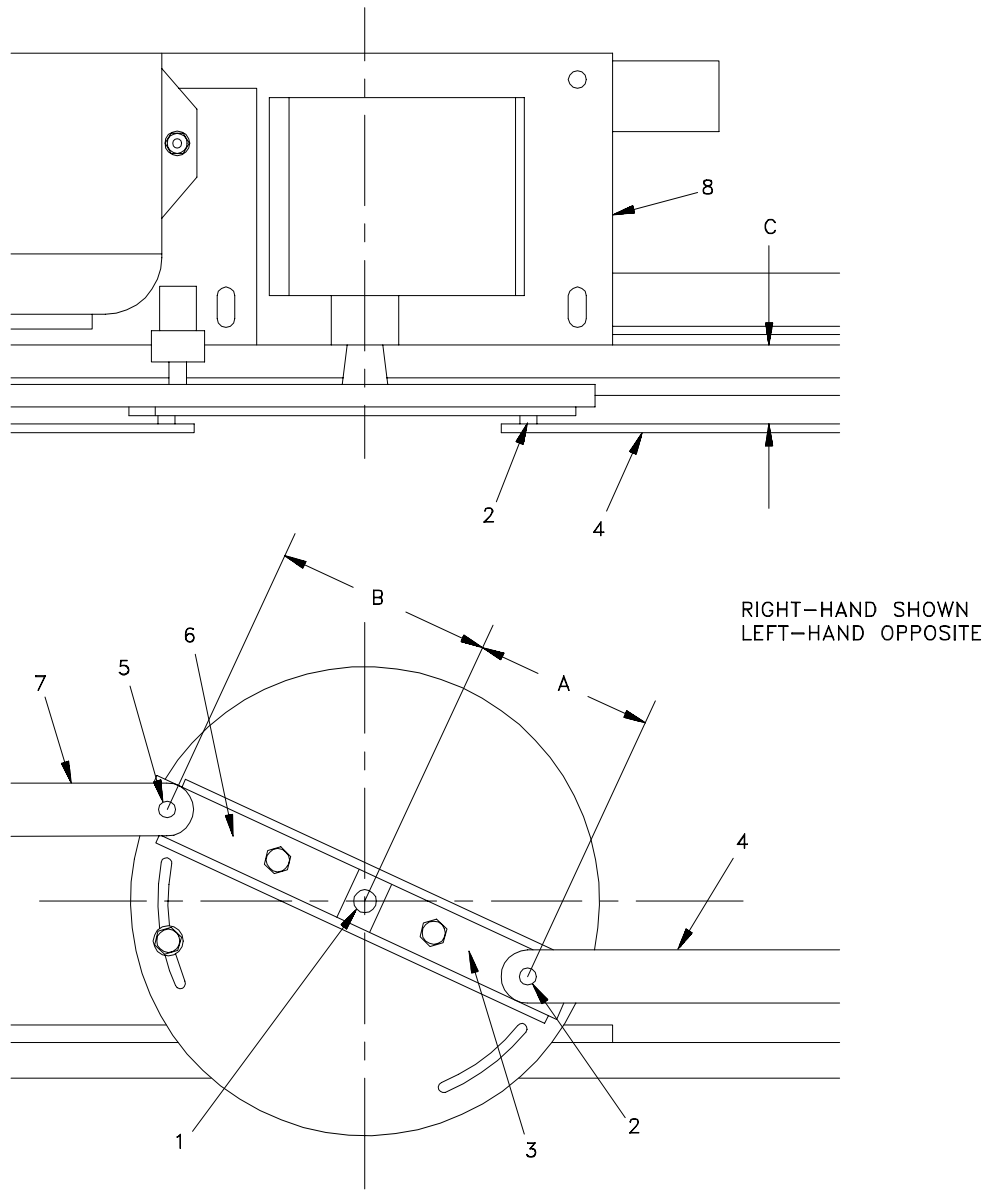

Z604-007(11/94)

MOD style (center-opening)



Removing components MOD style (center-opening)

Ensure that all critical dimensions have been recorded before removing any components.

For more information on critical dimensions, refer to section titled: *Recording Critical Dimensions - MOD style (center-opening)*.

1. Turn off electrical power to the door operator.
2. Remove bolts and nuts (1 & 2) and crank arms (3 & 4) from drive sheave (5). Save bolts and nuts (1 & 2) and crank arms (3 & 4) for use when installing MAC® door operator.
3. Tag and disconnect the gate switch wiring before removing flexible conduit (6) from control box (7). Tag and disconnect the door operator control wiring from the car junction box.
4. Remove four bolts from bearing block (8) and two bolts from adjusting bolt bracket (9).
5. Remove chain (10) and belt (11) from intermediate sheave (12).
6. Remove bearing block (8), intermediate sheave (12), belt (11), and adjusting bolt bracket (9) from baseplate (13).
7. Remove hardware from motor mounting guide stud (14) and four bolts from motor mount assembly (15).
8. Remove motor (16) and motor mount assembly (15) from baseplate (13).
9. Use Vise-grip pliers to remove the motor mounting guide stud (14) from baseplate (13).
10. Remove wingnut (17) and cover from control box (7).
11. Remove two bolts, control box (7), and mounting plate (18) from baseplate (13).
12. Remove four bolts from bearing block (19). Remove bearing block (19), chain (10) and drive sheave (5) from baseplate (13).
13. Remove two bolts and stop roller bracket (20) from baseplate (13).
14. After removing the MOD style components, there are no parts left on baseplate (13).

A604-010 (1/95)

Door Operator Conversion

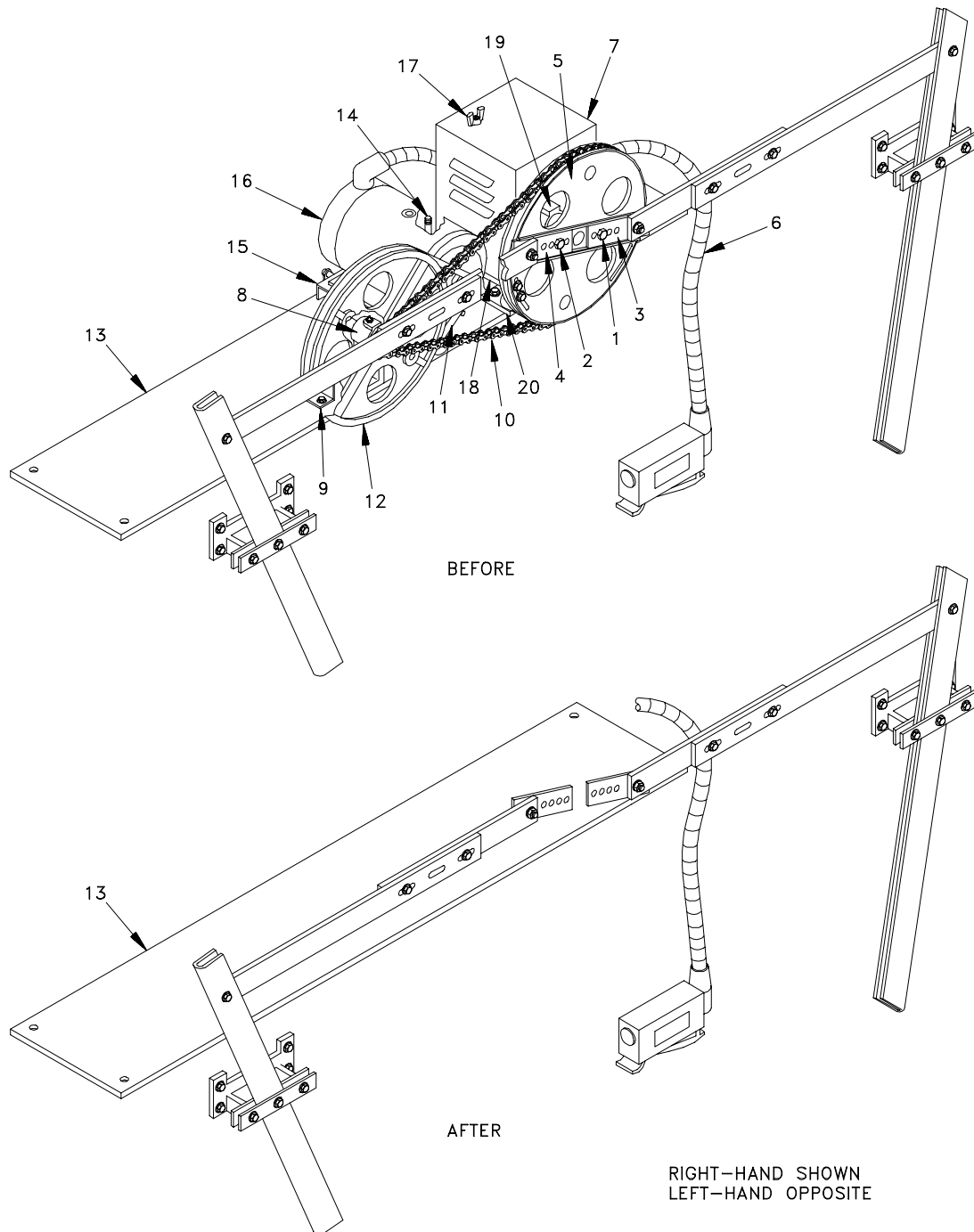

Z604-003(1/95)

MOD style (center-opening)



Door Operator Conversion

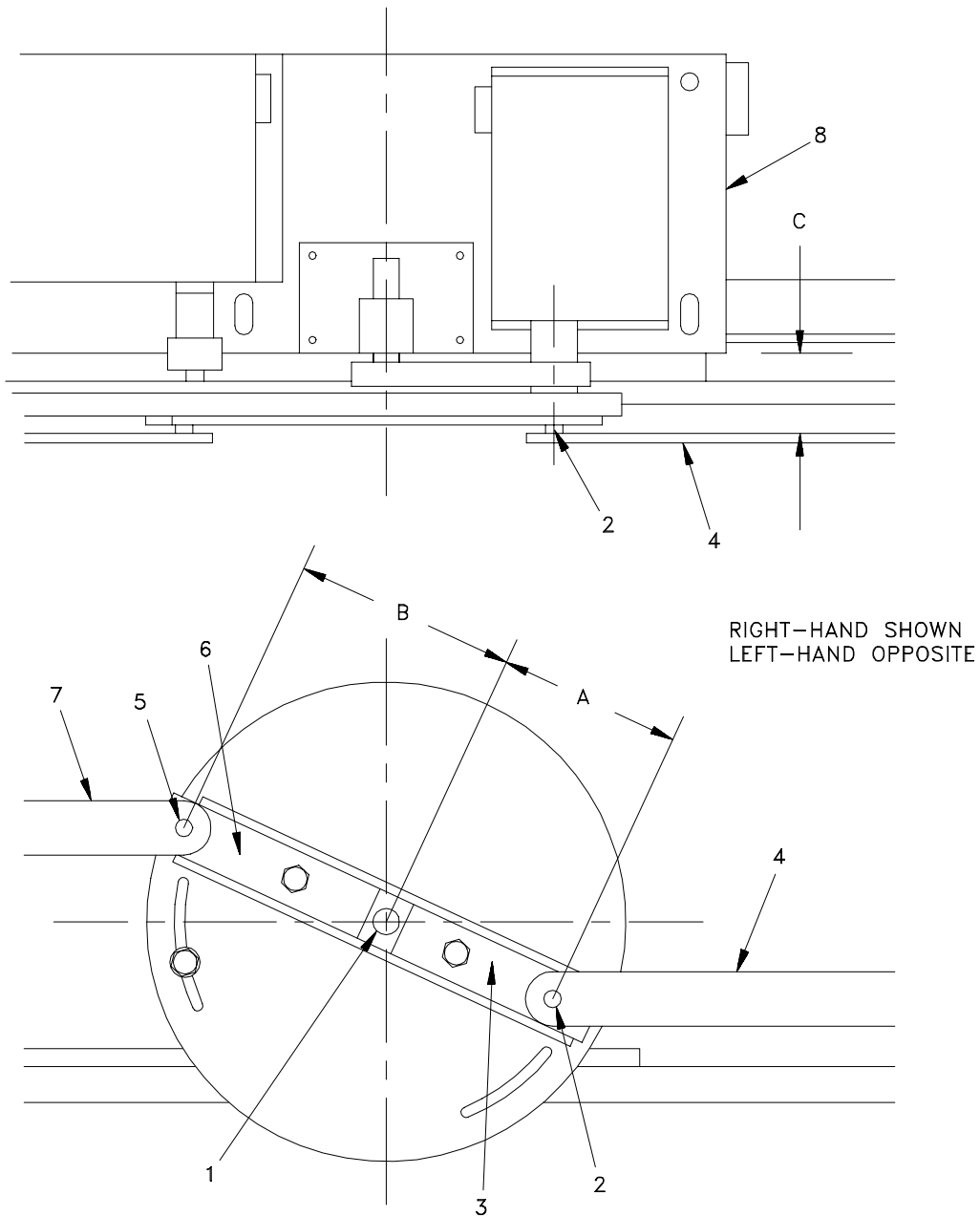

Z604-008(11/94)

MOM & MOH styles (center-opening)



Removing components - MOM & MOH styles (center-opening)

Ensure that all critical dimensions have been recorded before removing any components.

For more information on critical dimensions, refer to section titled: *Recording Critical Dimensions MOM & MOH styles (center-opening)*.

1. Turn off electrical power to the door operator.
2. Remove bolts and nuts (1 & 2) and crank arms (3 & 4) from drive sheave (5). Save bolts and nuts (1 & 2) and crank arms (3 & 4) for use when installing MAC[®] door operator.
3. Tag and disconnect the gate switch wiring before removing flexible conduit (6) from control box (7). Tag and disconnect the door operator control wiring from the car junction box.
4. Remove four bolts from bearing block (8) and two bolts from adjusting bolt bracket (9).
5. Remove chain (10) and belt (11) from intermediate sheave (12).
6. Remove bearing block (8), intermediate sheave (12) and adjusting bolt bracket (9) from baseplate (13).
7. Remove hardware from motor mounting guide stud (14) and four bolts from motor mount assembly (15).
8. Remove motor (16) and motor mount assembly (15) from baseplate (13).
9. Use Vise-grip pliers to remove the motor mounting guide stud (14) from baseplate (13).
10. Remove four bolts and control box (7) from baseplate (13).
11. Remove four bolts and terminal box (18) from baseplate (13).
12. Remove four bolts from bearing block (19). Remove chains (10 & 20), bearing block (19) and drive sheave (5) from baseplate (13).
13. Remove two bolts and stop roller bracket (21) from baseplate (13).
14. After removing the MOM & MOH style components, there are no parts left on baseplate (13).

A604-012 (1/95)

Door Operator Conversion

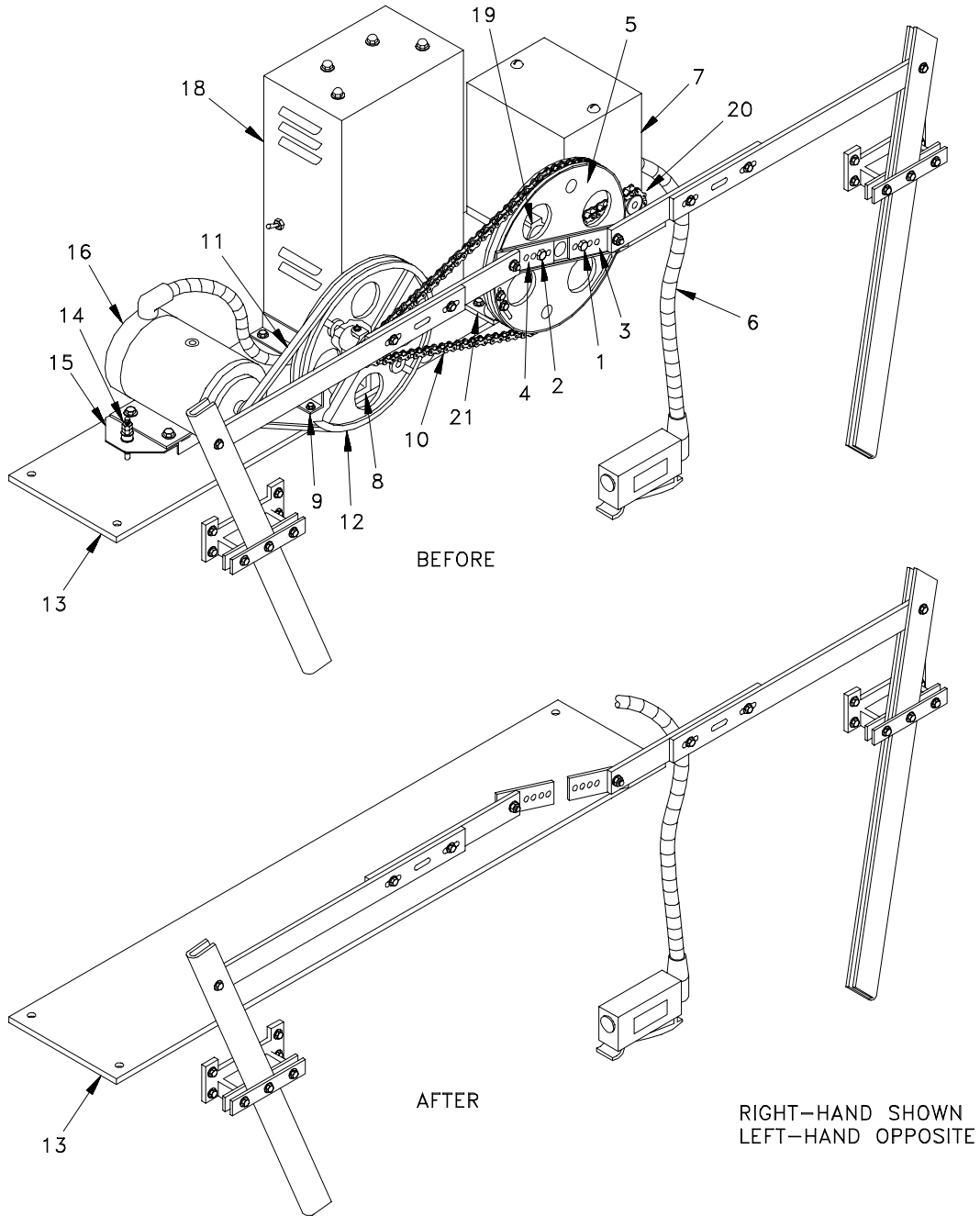

Z604-004(1/95)

MOM & MOH styles (center-opening)



Installing MAC® door operator

Before installing the MAC® door operator, refer to the appropriate style table where you recorded the critical GAL® door operator dimensions. These recorded dimensions make it easier to install the MAC® door operator. Use the following procedures to install the MAC® door operator on the GAL® baseplate.

INSTALL MAC® DOOR OPERATOR (SIDE-OPENING DOOR)

1. Set the new MAC® door operator (1) on the existing GAL® baseplate (2).
2. Remove the three nuts and lockwashers (3) that hold adapter plate (5) to sheave (6).

There are spacers (4) between the adapter plate (5) and sheave (6). Use caution so you don't lose any of the spacers while removing the adapter plate (5) from sheave (6).
3. Remove adapter plate (5) from sheave (6).
4. On the top adapter bar (7), measure 6-3/4 inches from one end, and scribe a line.
5. Install the GAL® crank arm (8) on the adapter plate (5) with the bolts (9) and nuts (10) saved during the GAL® *Removing Components* procedure. **Do not tighten the bolts at this time.**
6. Measure the distance from the scribe line on top adapter bar (7) to the center of the pivot point (12). The measurement should be the same as the "B" measurement recorded during the GAL® *Recording Critical Dimensions* procedure.
7. Adjust the position of the crank arm (8) on the adapter plate (5) until it is the same as the "B" measurement. Tighten bolts (9). The crank arm "B" measurement is the stroke of the operator. If the GAL® door operator measurement was accurate, then this is a good starting point for setting the stroke of the MAC® door operator.
8. Install adapter plate (5) with GAL® crank arm (8) on sheave (6) using bolts, lockwashers and nuts (3) and spacers (4).
9. Turn sheave (6) by hand until the pivot point (12) and crank arm (8) are parallel to the baseplate (2).
10. Measure the distance between the back of crank arm (8) and the mounting plate (2). The measurement should be the same as the "C" dimension recorded during the GAL® *Recording Critical Measurements* procedure. Move the MAC® door operator until the "C" dimension is the same.
11. Square the MAC® door operator to baseplate (2) while maintaining the "C" dimension for the crank arm (8). The "B" and "C" measurements should align the connecting link arm (13) and crank arm (8) with the MAC® door operator.
12. Temporarily clamp the MAC® door operator to baseplate (2) to prevent it from moving.
13. Turn sheave (6) by hand until the car doors are in a "completely open" position. If "completely open" position can't be reached, loosen the hold-down clamps on the MAC® door operator. Carefully shift door operator from side-to-side until doors are "completely open".
14. Turn sheave (6) by hand until the car doors are in a "completely closed" position.
15. Adjust the stroke and the side-to-side position of the door operator for "completely open" and "completely closed" positions. Stroke is the distance from scribe line on top adapter bar (7) to the center of pivot point (12) for crank arm (8) and connecting link arm (13).

Increasing the stroke allows the doors to travel more in the open and closed directions. Decreasing the stroke allows the doors to travel less in both directions.
16. Use existing holes in MAC® door operator end brackets (14) as a guide for drilling holes in baseplate (2).
17. Install nuts and bolts (15) in drilled holes.

Refer to section "*Wire door operator*" for information on wiring MAC® door operator.

A604-013 (1/95)

Door Operator Conversion

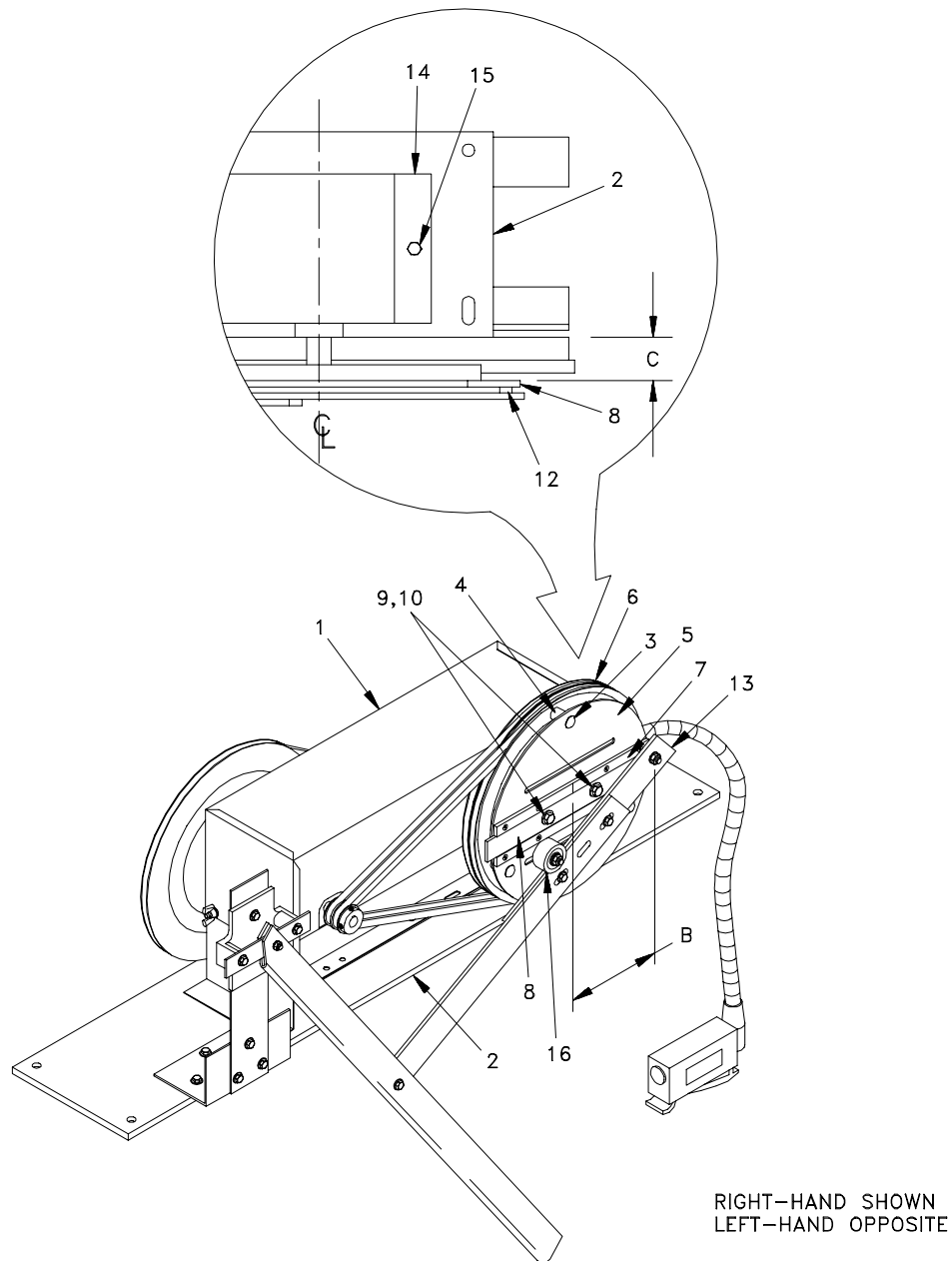

Z604-010(11/94)

GAL[®]-to-MAC[®] door operator (side-opening)



INSTALL MAC® DOOR OPERATOR (CENTER-OPENING DOORS)

1. Set the new MAC® door operator (1) on the existing GAL® baseplate (2).
2. Remove the three nuts and lockwashers (3) that hold adapter plate (5) to sheave (6).

There are spacers (4) between the adapter plate (5) and sheave (6). Use caution so you don't lose any of the spacers while removing the adapter plate (5) from sheave (6).
3. Remove adapter plate (5) from sheave (6).
4. On the top adapter bar (7), measure 6-3/4 inches from one end, and scribe a line.
5. Install the GAL® crank arms (8 & 9) on the adapter plate (5) with the bolts and nuts (10) saved during the GAL® *Removing Components* procedure. **Do not tighten the bolts at this time.**
6. Measure the distance from the bottom of scribed line on adapter bar (7) to the center of the pivot point (12) for the crank arm (8). The measurement should be the same as the "A" measurement recorded during the GAL® *Recording Critical Measurements* procedure.
7. Adjust the position of the crank arm (8) on the adapter plate (5) until it is the same as the "A" measurement. Tighten one of bolts (10).
8. Measure the distance from the bottom of scribed line on adapter bar (7) to the center of the pivot point (14) for the crank arm (9). The measurement should be the same as the "B" measurement recorded during the GAL® *Recording Critical Measurements* procedure.
9. Adjust the position of the crank arm (9) on the adapter plate (5) until it is the same as the "B" measurement. Tighten the other bolt (10).
10. Install adapter plate (5) with GAL® crank arms (8 & 9) on sheave (6) using bolts, lockwashers and nuts (3).
11. Turn the sheave (6) by hand until the pivot point (12) and crank arm (8) are parallel to the baseplate (2).
12. Measure the distance between the back of connecting link arm (13) and the mounting plate (2). The measurement should be the same as the "C" dimension recorded during the GAL® *Recording Critical Measurements* procedure. Move the door operator until the "C" dimension is the same.
13. Square the MAC® door operator to baseplate (2) while maintaining the "C" dimension for the connecting link arm (13). The "A", "B", and "C" measurements should align the connecting link arms (13 & 15) and crank arms (8 & 9) with the MAC® door operator.
14. Temporarily clamp the MAC® door operator to baseplate (2) to prevent it from moving.
15. Turn sheave (6) by hand until the car doors are in a "completely open" position. If "completely open" position can not be reached, loosen the hold-down clamps on the MAC® door operator. Carefully shift door operator from side-to-side until doors are "completely open".
16. Turn sheave (6) by hand until the car doors are in a "completely closed" position.
17. Adjust the stroke and the side-to-side position of the door operator for "completely open" and "completely closed" positions. Stroke for crank arm (8) is the distance from the bottom of scribe line on adapter bar (7) to the center of pivot point (12). Stroke for crank arm (9) is the distance from the bottom of scribe line on adapter bar (7) to the center of pivot point (14).

Increasing the stroke allows the doors to travel more in the open and closed directions. Decreasing the stroke allows the doors to travel less in both directions.
18. Adjust door stop bolt (19) so it stops door roller (18) when the doors are fully closed.

Right-hand center opening. Door roller (18) shown as viewed from the top.

Left-hand center opening. Door roller (18) shown as viewed from the left end.
19. Use existing holes in MAC® door operator end brackets (16), for drilling holes in mounting plate (2).
20. Install bolts and nuts (17) in drilled holes.

Refer to section "*Wire door operator*" for information on wiring MAC® door operator.

A604-014 (6/96)

Door Operator Conversion

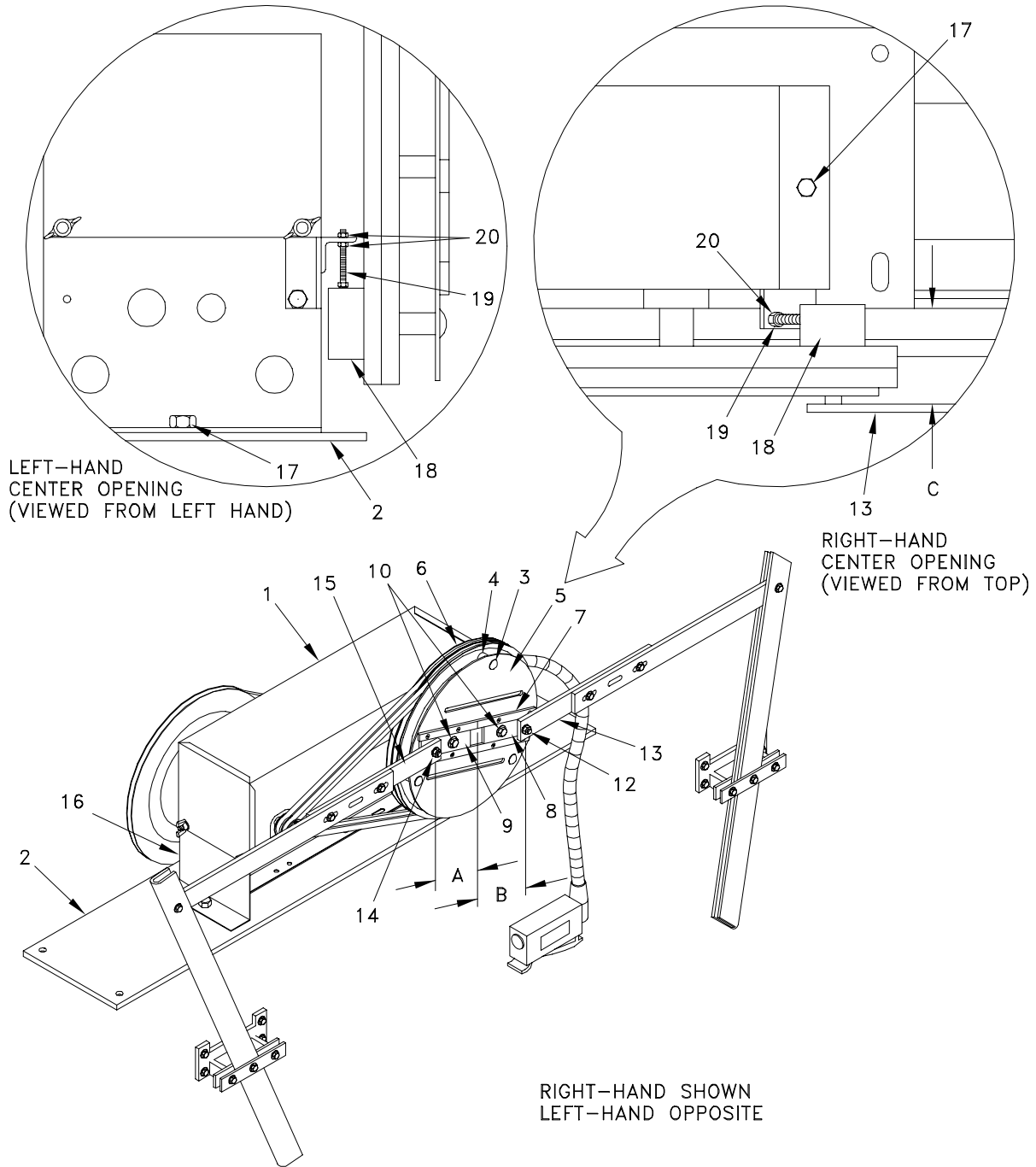

Z604-011(6/96)

GAL[®]-to-MAC[®] door operator (center-opening)



WIRE DOOR OPERATOR

1. Install and secure field wiring conduit (1) to appropriate knockout (2) in operator base.

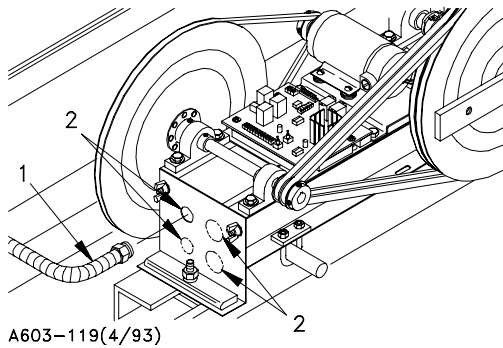

2. Pull traveling cable wires from elevator controller, and connect them to L1A, L2A, DO7, DO10, and DO3 of terminal block TB-1 (3).

If you are unable to direct-wire, connect one end of a line cord to L1A and L2A. Wire the other end into a separately fused, non-switched 115 VAC power supply from the elevator control system.

3. If the existing relay logic controller has circuitry for nudging, connect a traveling cable wire to DO4.

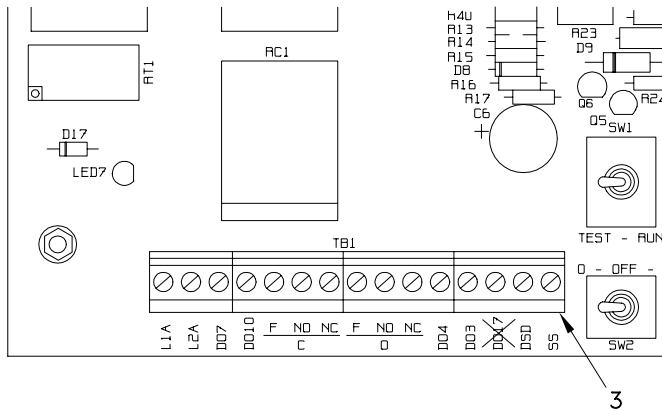

Z604-016(1/96)

4. Connect a traveling cable wire to the Normally Closed contact (4) on cam microswitch DO17.

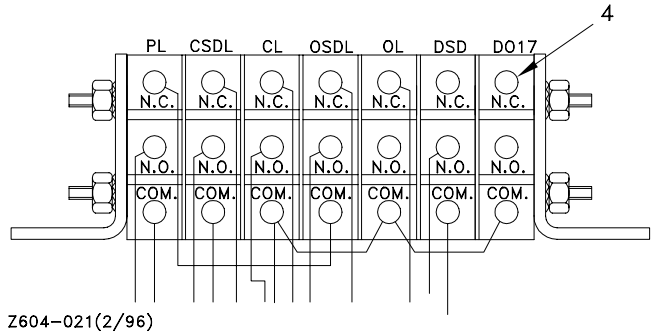

5. Connect a traveling cable wire to DO18 (5) on 104 Auxiliary Locking Board.

A604-015 (7/96)

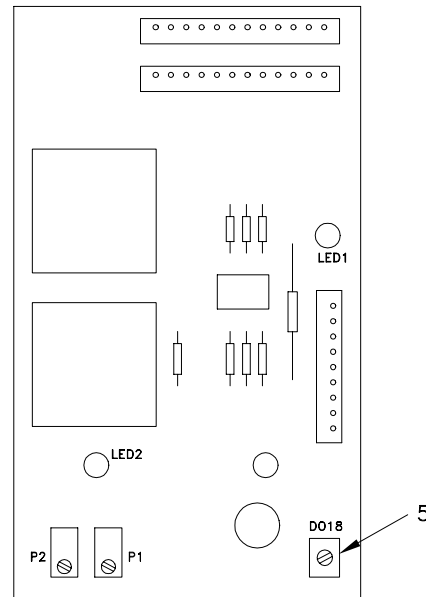

Z604-020(1/96)

WIRE GATE SWITCH

Wire gate switch to existing car gate circuit from controller. Consult controller schematics for proper connections.

A604-016 (1/95)

Input & Output Terminals & DO17 Cam operated microswitch

L1A to L2A	120VAC @ 500VA input. If one of the input lines is grounded, it should be connected to L1A.	L1A to DO18	Door locking signal. When a relay contact across these terminals is made up, and the doors have a signal to close, the doors close and hold against mechanical stop.
DO3 to L1A	Open limit signal. A relay across these terminals will be de-energized when the open limit microswitch is actuated. Relay will be energized at all other times.	L1A to DO4	Reduced speed closing signal. When the doors have a signal to close, and a relay contact across these terminals is made up, the door speed is controlled by "N" potentiometer.
DO7 to L1A	Signal to close. When a relay contact across these terminals is made up, the doors will close.	<u>F NC NO</u>	Auxiliary C relay switching contact. Designates a Form "C" contact on a 1-C relay.
DO10 to L1A	Signal to open. When a relay contact across these terminals is made up, the doors will open.	<u>F NC NO</u>	Auxiliary O relay switching contact. Designates a Form "C" contact on a 1-O relay.
DO17(NC) to L1A	Close limit signal. A relay across these terminals will be de-energized when the close limit microswitch is actuated. Relay will be energized at all other times.	<u>DSD to SS</u>	Optional - Used on some projects for load balancing or other customer requirements.

A604-S14 (1/96)

Wiring to MIPROM controller

MIPROM controllers have terminals on I/O boards that connect to like terminals on the door operator.

A604-S18 (1/96)



Wiring non-MIPROM logic controller

The existing door open limit contact, door close limit contact, and any connections used to feed the GAL door motor are no longer needed. The travel cable wires may be connected to other new functions. Remove the GAL door resistors, fuses, capacitors, and rectifier (if the door motor circuit was the only load). The Open and Close relays are used, but they are rewired. If the contacts are worn, replace the contacts or relays.

1. The MAC door operator requires 120VAC @ 500VA power. Review the existing controller wiring diagrams to see if this power is available from the controller. If not, a step-down transformer is required to step down the line voltage to 120 VAC.
2. For most conversions, three relays, (DOL, DCL and RUN) have to be added to existing relay logic controllers. The DOL (1) and DCL (2) relays require 120 VAC coils. The RUN relay requires a coil (3) with the same voltage as the Door Close relay on the relay logic controller. The relay contacts should be large enough to handle the voltage/current feeding the existing open and close relay coils.
3. Disconnect the existing DOL limit switch (4).
4. Connect the traveling cable wire from DO3 to one side of the DOL relay coil (1). Connect the other side of the DOL relay coil to L1A.
5. Wire a normally open contact on DOL relay (5) to the terminals previously used by the GAL door open limit contact on the existing relay logic controller.
6. Connect the traveling cable wire from the Normally closed contact of microswitch DO17 to one side of the DCL relay coil (2). Connect the other side of the DCL relay coil to L1A.
7. Disconnect the existing DCL limit switch (6).
8. Wire the Normally Open contact on one pole of DCL relay (7) to the terminal on the line side. Wire the common of that pole to the other terminal where the GAL door close limit was wired.
9. Wire the N.C. contact on the same pole of DCL relay (8) to one side of the RUN relay coil (3).
10. Wire the other side of the RUN relay coil (3) to the return line side (9) of the existing GAL door close relay coil (10) circuit.

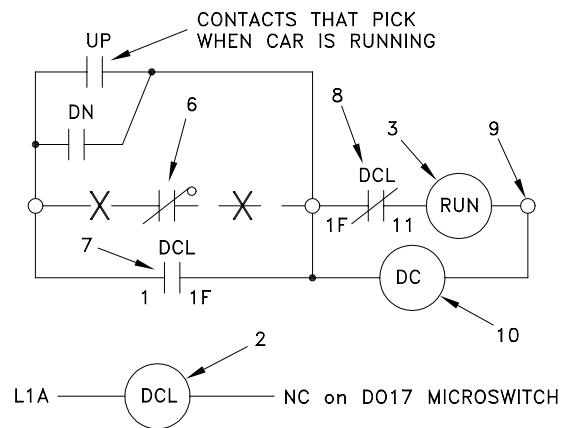
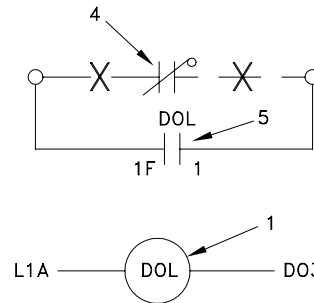

Z604-018(2/96)

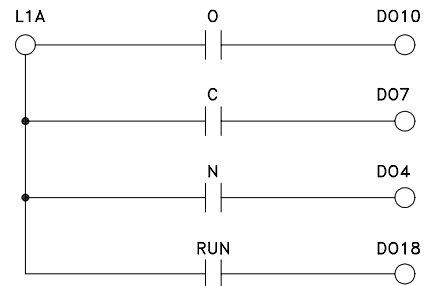

Contacts off: Existing Open & Close relays (if both used) and Nudging

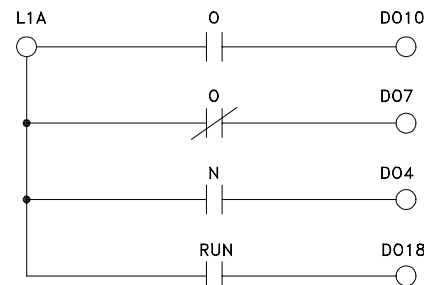

Z604-019(1/96)

Contacts off: Existing Open relay (if NO separate close relay was used) and Nudging

Adjusting door operator control Board 1Ø4™

The following describes instructions for adjusting the door operator control Board 1Ø4™.

- Measure current (optional)
- Set potentiometers
- Adjust door speeds
- Adjust door closing force
- Adjust nudge speed
- Set microswitch cams

Damage to the door operator control board can result if the following adjustment instructions are not followed carefully. If you cannot complete any of the following procedures as they are described, stop and request assistance.

A604-017 (1/95)

Toggle switches

To adjust and service the door control, use the two toggle switches on the door operator control Board 1Ø4™ — the TEST-RUN switch and the O-OFF-C switch.

- **TEST-RUN.** The TEST-RUN switch is normally in the RUN position. When the TEST-RUN switch is in the TEST position, it disconnects the normal open and close input signals from the door control, and switches the O-OFF-C toggle switch into the circuit.
- **O-OFF-C.** The O-OFF-C switch is normally in the OFF (center) position. This OFF position does not indicate that input power has been removed, it only indicates there is no signal to open or close when the TEST-RUN switch is in the TEST position.

A604-S15 (1/95)

MEASURE CURRENT (OPTIONAL)

CAUTION: Do not install an ammeter in the power supply line.

Current measurements are not required to adjust the door operator control Board 1Ø4™. Although, if you wish to measure current, do so as follows.

1. Connect a voltmeter to resistor R2 (.1 Ohm 5 watt resistor) located between heat sinks Q2 and D2.
 - Viewing from the TB1 side of the control board, the right side of resistor R2 is (-) and the left side of resistor R2 is (+).
2. Set the voltmeter to a low range — 1 volt or 2.5 volt.
3. Read the measurement, keeping the following in mind.
 - 1 volt on the meter indicates 10 amps of current.
 - .5 volt on the meter indicates 5 amps of current.

A604-018 (1/95)

SET POTENTIOMETERS

Make sure all potentiometers are to ZERO, except P8. Do not set potentiometer P8. It is factory-set and sealed.

You will feel a click when potentiometers reach either end of their travel. It is acceptable to turn the potentiometer past these points because of a built-in slip clutch at each end. These multi-turn potentiometers require 25 turns to traverse their complete range.

A604-019 (1/95)

Cutting top circuit trace on Door Board 104

To have the door operator function as required, a circuit trace on the Board 104 must be cut. The trace is the top trace of the eight jumper traces located immediately to the left of the green LEDs that indicate the speed potentiometers.

Cut only the top trace as shown.

Check the board to make sure the top trace is cut before proceeding with any procedures.

A604-S19 (8/98)

**Cut this trace only.
Use utility knife or pocket knife.**

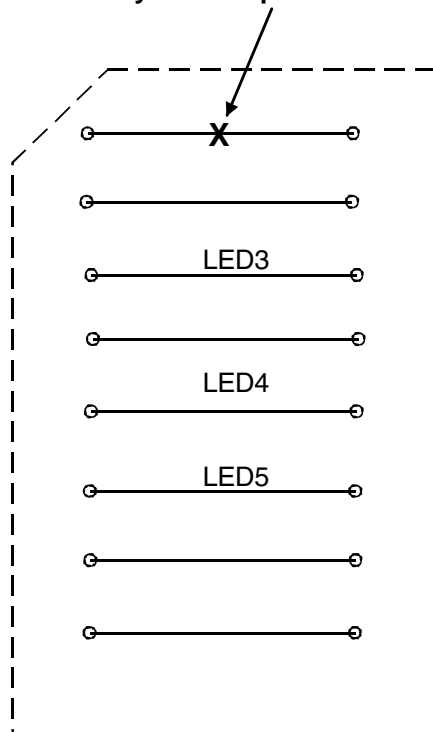

A604-113 (8/98)

ADJUST DOOR SPEEDS

1. Set switches and potentiometer in the following positions.
 - All speed control potentiometers - fully counter-clockwise.
 - C.C.L. potentiometer - Fully clockwise.
 - TEST-RUN switch - TEST position.
 - O-OFF-C switch - OFF (center) position.
 - Two position jumper J4 - just to the right, and slightly above, the R01 relay. (*Standard* position if one pair of wires are present at TB3. *High Performance* if two pair of wires are present at TB3.)
2. Apply power. Then, toggle the O-OFF-C switch to the “O” position. LED6 next to the “PL” potentiometer will illuminate, indicating the doors are in the PL zone.
3. Turn “PL” potentiometer clockwise until doors begin to open. When the “PL” microswitch is dropped, the LED next to the “PL” potentiometer will go out, and the LED next to the “OF” potentiometer will illuminate.
4. Turn the “OF” potentiometer clockwise, just enough to move the doors through the “OF” speed zone. When the “OSDL” microswitch is dropped by its CAM, the LED next to the “OF” potentiometer will go out, and the LED next to the “OS” potentiometer will illuminate.
5. Turn the “OS” potentiometer, just enough to move the door through the “OS” speed zone. When the “OL” CAM is activated by its microswitch, the LED next to the “OS” potentiometer will go out. The doors will now be fully open.
6. Toggle the O-OFF-C switch to the C position. The LED next to the “CF” potentiometer will come on.
7. Turn the “CF” potentiometer clockwise until the doors begin to move. When the “CSDL” microswitch is dropped by its CAM the LED next to the “CF” potentiometer will go out and the LED next to the “CS” potentiometer will illuminate.
8. Turn the “CS” potentiometer clockwise until the “CL” microswitch is actuated by its CAM. The LED next to the “CS” potentiometer will go out. The doors will now open and close at slow speed.

In the event the doors do not fully open or close within 10 to 15 seconds, the internal timer will remove motor power.
9. Using the speed zone potentiometer and settings of the CAMS, adjust door speeds for the desired performance. The green LED's indicate which speed control potentiometer is controlling the door speed.
 - **Increase door speed** — turn potentiometer *clockwise*
 - **Decrease door speed** — turn potentiometer *counterclockwise*

Do not set potentiometer P8. It is factory-set and sealed.

A604-020 (1/95)

TIP: If the doors do not operate smoothly, particularly on slower moving doors, it may help to remove the jumper J3. This eliminates the dynamic braking, and will allow a smoother transition between speeds.

A604-S16 (1/95)

Door Operator Conversion

Make sure top jumper trace is cut, before starting any procedures.

For more information on top jumper trace, refer to special instructions within this section titled: *Cutting top circuit trace on Door Board 104.*

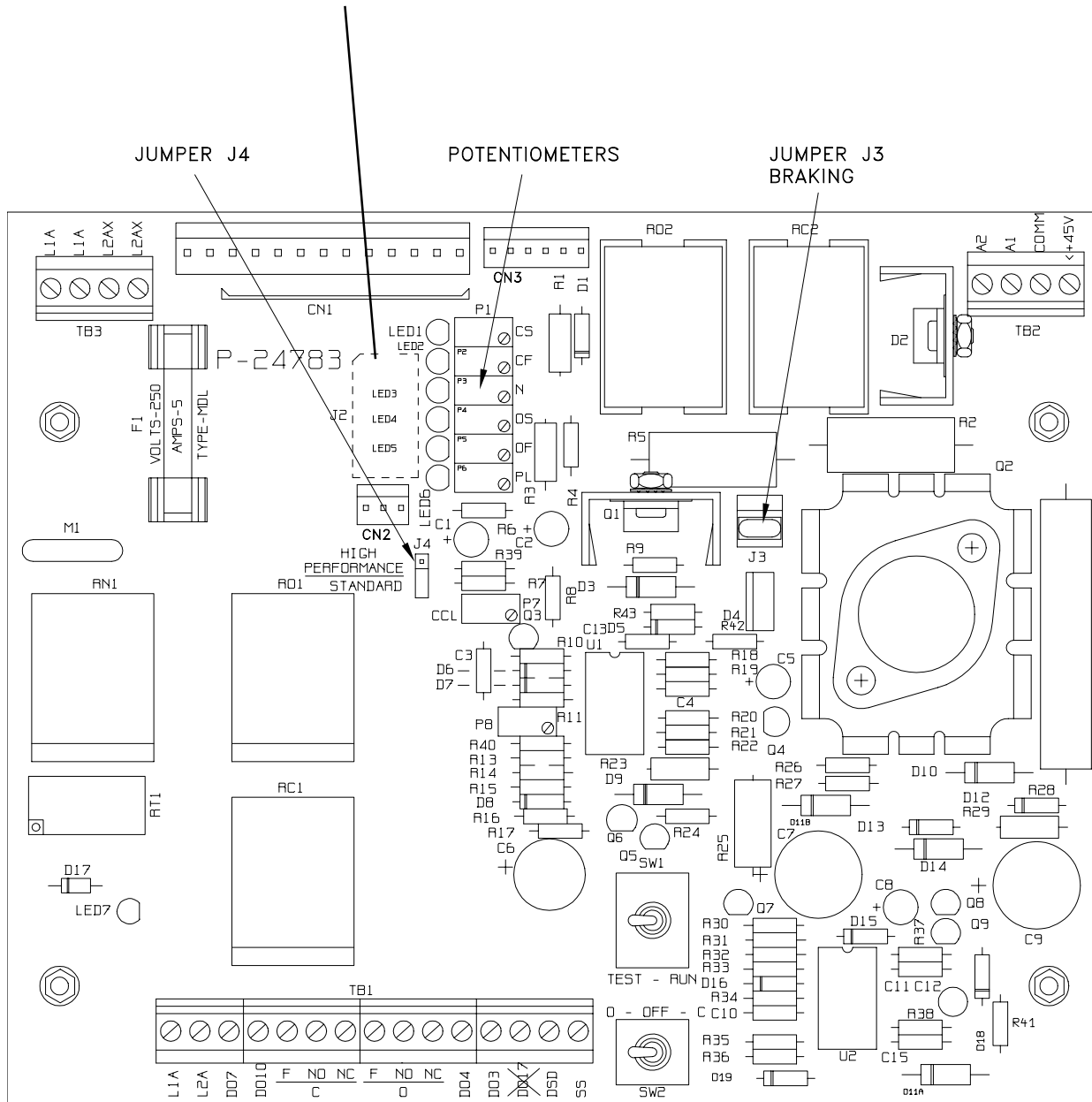

Z604-015(2/96)
A603-121(2/95)



ADJUST DOOR CLOSING FORCE

The following describes the adjustment procedure used to set door closing force.

1. Toggle the TEST-RUN switch to the TEST position.
2. Stop the doors at the mid-point in the closing direction by toggling the O-OFF-C switch to the OFF position.
3. Turn the close current limit CCL potentiometer fully counter-clockwise until the doors stall.
4. Turn the CCL potentiometer clockwise until the desired door close operation is achieved. This should put door closing force below the 30 pound maximum allowed by Code.
5. To check door pressure, physically stall the door at the midpoint in the closing direction. Then, place the rubber end of a pressure gauge (1) on the edge of the power-driven car door (3). Read pounds of force (2) on gauge and record the results.
6. Open and close the doors with the O-OFF-C switch several times.
7. Physically stall the doors again in the closing direction and re-check the door closing force with the pressure gauge.

If the door closing force CANNOT be kept under 30 pounds, contact Moline Accessories Company.

A604-021 (1/95)

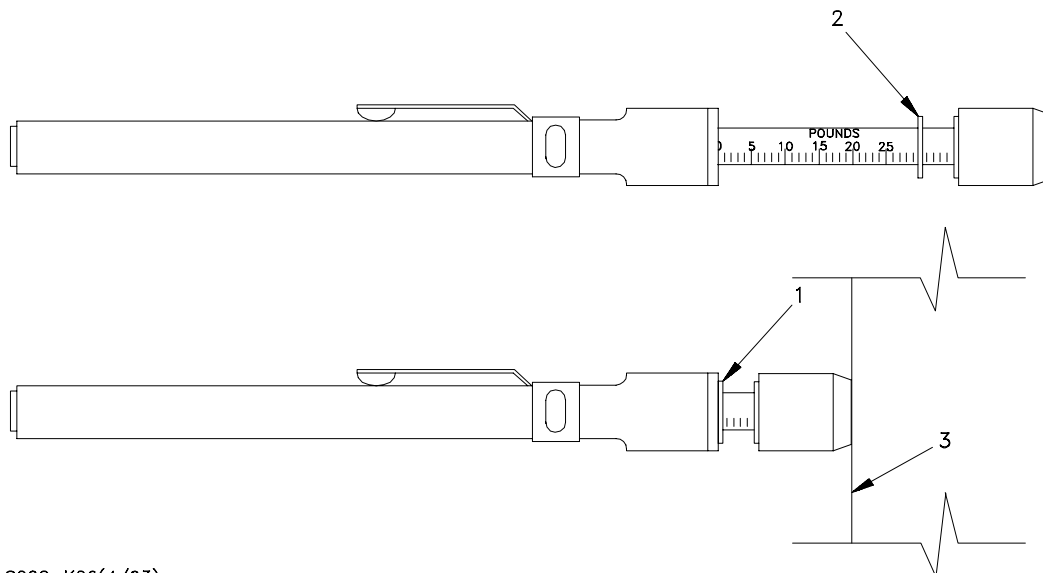

C202-K26(4/93)

ADJUST NUDGE SPEED

1. Make sure there is a signal for the nudge function.
 - *If there is a signal for nudging, the LED by the N potentiometer is ON.*
 - *If there is NOT a signal for nudging, check the input signal.*

For more information about checking input signals, refer to INSTALLING MAC DOOR OPERATOR/Wire door operator/Input & output terminals.

2. Simulate a nudge signal by placing a jumper on the TB-1 terminal strip between L1A and DO4. Place the TEST-RUN switch in TEST position. Place O-OFF-C switch in C position. Doors will close at nudge speed.

You cannot adjust nudge speed with TEST-RUN switch in TEST position.

3. Turn the N potentiometer clockwise until desired nudging speed is reached.
4. Remove jumper before returning the TEST-RUN switch to RUN.

A604-022 (1/95)

When all adjustments are complete, place the O-OFF-C switch in the OFF position, and the TEST-RUN switch in the RUN position. *Replace the door operator cover.*

A604-S17 (1/95)



SET MICROSWITCH CAMS

The microswitch cams of the PM/SSC door operator determine where changes in door speed occur. Factory settings are approximate. Set microswitch cams, if necessary, per individual job requirements.

- CL** CAM will actuate CL microswitch when doors are in their desired fully closed position.
- PL** Initial opening CAM will drop microswitch when car door clutch has just engaged both hoistway door rollers, but will not drop microswitch if door interlock hangs up.
- OSDL** CAM will drop OSDL microswitch when doors are approximately half open.

- CSDL** CAM will drop CSDL microswitch when doors are approximately four inches from their fully closed position.
- OL** CAM will actuate OL microswitch when doors are in fully open position.
- DSD** CAM will actuate DSD microswitch when doors are approximately 4 to 6 inches from fully closed position when used with load balancing. CAM can also be set for other customer requirements.
- DO17** CAM will actuate DO17 microswitch when doors are in their desired fully closed position.

A604-023 (1/95)

Door Operator Conversion

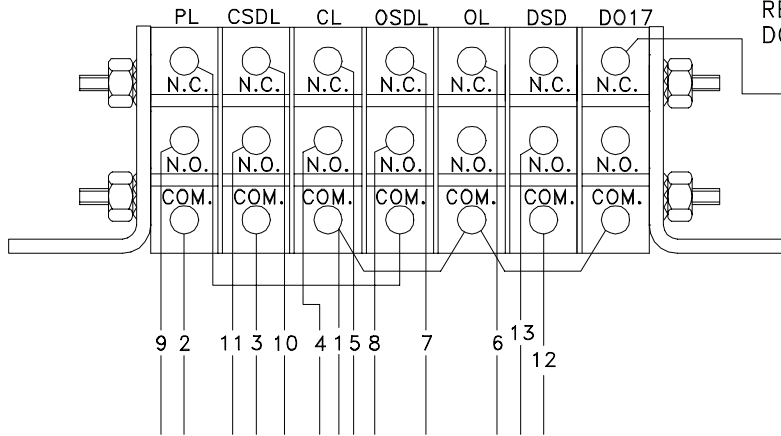

CONNECT TO DCL RELAY COIL ON RELAY LOGIC CONTROLLERS, OR D017 ON MIPROM I/O BOARD.

NOTE:
WIRES #12 AND #13 ARE SHIPPED WITH THE ENDS TAPED. WHEN REQUIRED, CONNECT WIRE #12 TO COM ON DSD AND WIRE #13 TO N.O. ON DSD.

- WIRE DESIGNATION:
- #1 BLACK
 - #2 RED
 - #3 YELLOW
 - #4 BLUE
 - #5 BROWN
 - #6 ORANGE
 - #7 GREY
 - #8 VIOLET
 - #9 WHITE/BLACK
 - #10 WHITE/RED
 - #11 WHITE/GREEN
 - #12 WHITE/YELLOW
 - #13 WHITE/BLUE

Z604-012(7/96)



ADJUST BOARD 1Ø4™ WITH AUXILIARY LOCKING BOARD

- Adjust Board 1Ø4™ door speeds and closing force.

For more information on adjusting Board 1Ø4™ door speeds and closing force, refer to sections titled: *Adjust door speeds and Adjust door closing force.*

- Disconnect power from door operator.
- Turn auxiliary locking board potentiometer P2 (1) counter-clockwise.
- Place door operator in fully open position.
- Place Board 1Ø4™ RUN-TEST switch (2) in "TEST" position.
- Connect jumper from L1A (3) to DO7 (4).
- Apply power to door operator.
- Throw RUN-TEST switch (2) to "RUN" position.
 - Operator should close normally and stop when CL microswitch is actuated.
- Connect DO7 (4) to DO18 (5).
 - LED2 (6) should light.
- Turn potentiometer P2 (1) clockwise until door operator begins to move. Allow it to run slowly to its mechanical stop, then turn P2 clockwise until LED1 (7) lights.
- Remove jumper from DO18 (5).
 - LED2 (6) should go out, and door operator should relax.
- Throw TEST-RUN switch to "TEST" position. Throw O-OFF-C switch (7) to "O" position.
 - Door operator should run open. Allow door operator to open fully.
- Throw TEST-RUN switch to "RUN" position, and connect DO7 (4) to DO18 (5) before operator reaches closed limit.
 - When limit is reached, LED2 (6) should illuminate when limit is reached.
 - Door operator should close and hold against mechanical stop.
- Remove jumper from DO18 (5) and manually open operator until CSDL microswitch is actuated.

- Connect DO7 (4) to DO18 (5).

- LED2 (6) should light and operator should close and hold against mechanical stop.

Leave jumper connected for approximately 60 seconds to insure the timer on Board 1Ø4™ will not actuate.

- Remove power and jumpers.

A604-024 (1/95)

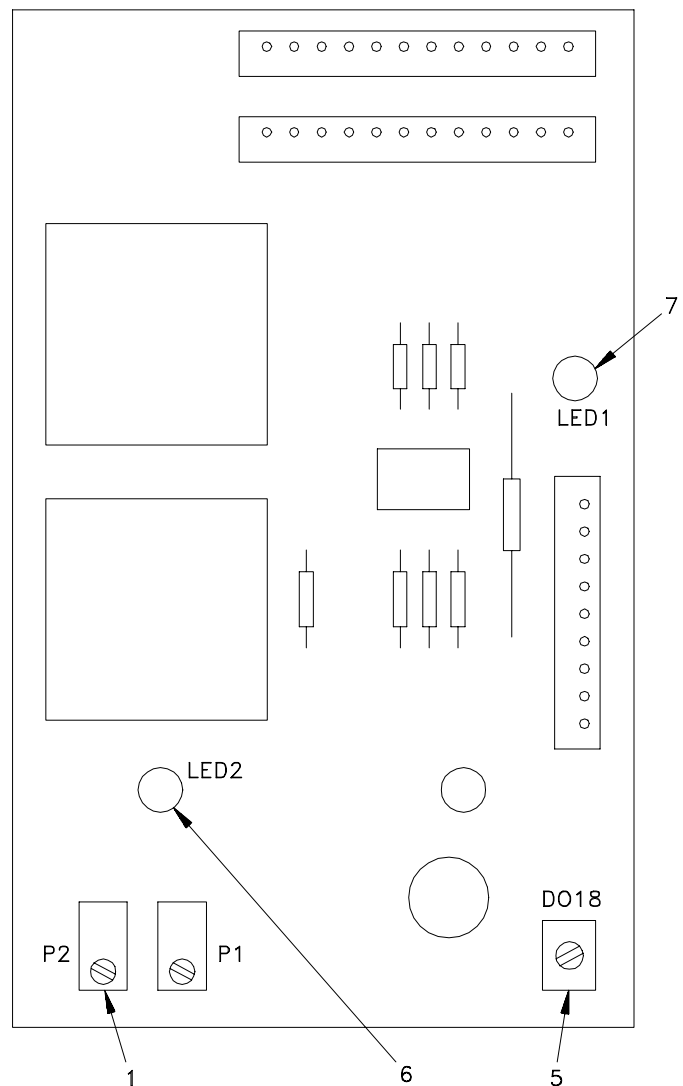

A603-116(1/95)

Auxiliary locking board

Door Operator Conversion

Make sure top jumper trace is cut, before starting any procedures.

For more information on top jumper trace, refer to special instructions within this section titled: *Cutting top circuit trace on Door Board 104.*

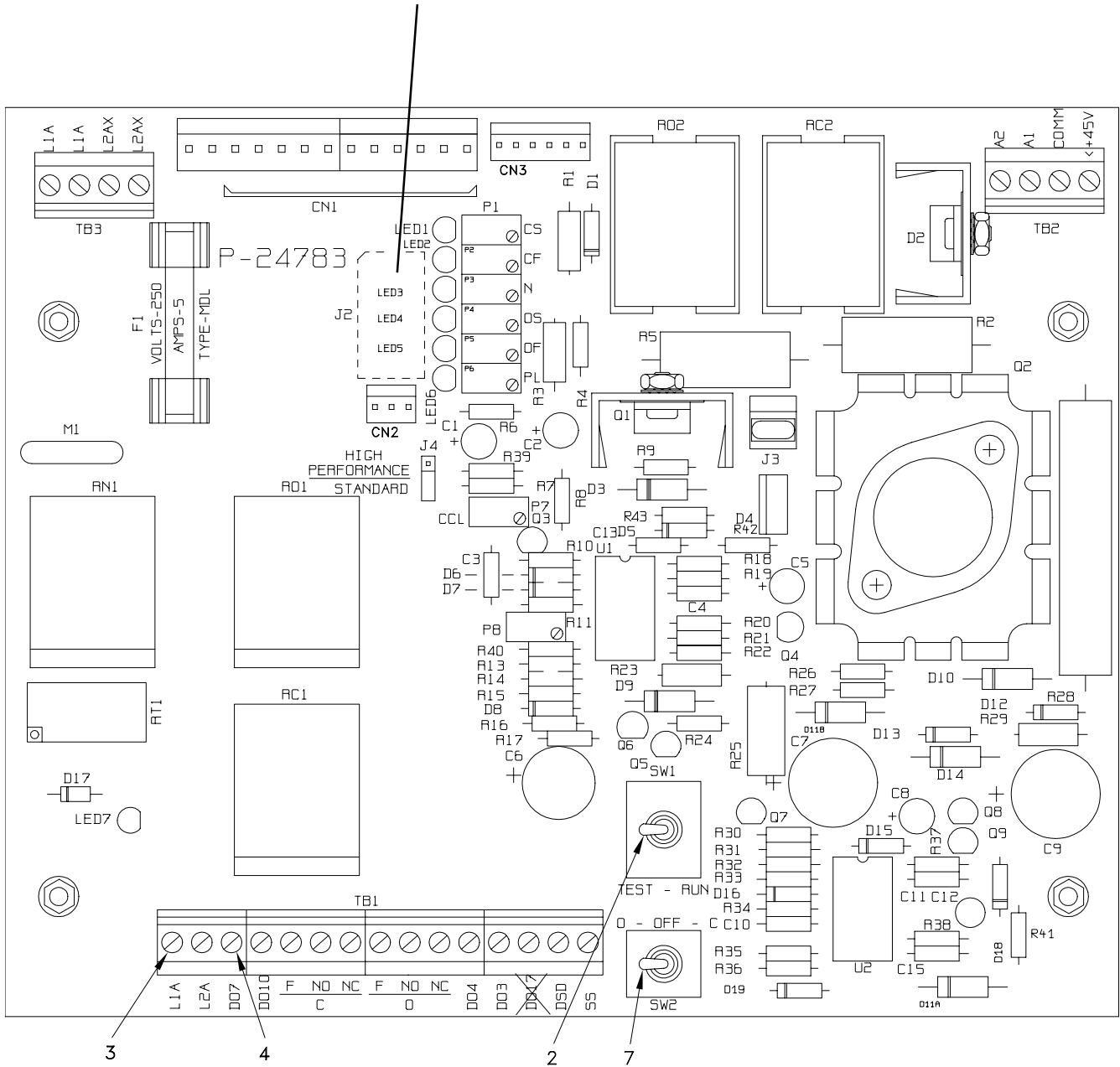

A603-117(2/96)

Board 104™



Replacement Parts

GAL®-to-MAC® SIDE-OPENING DOOR OPERATOR

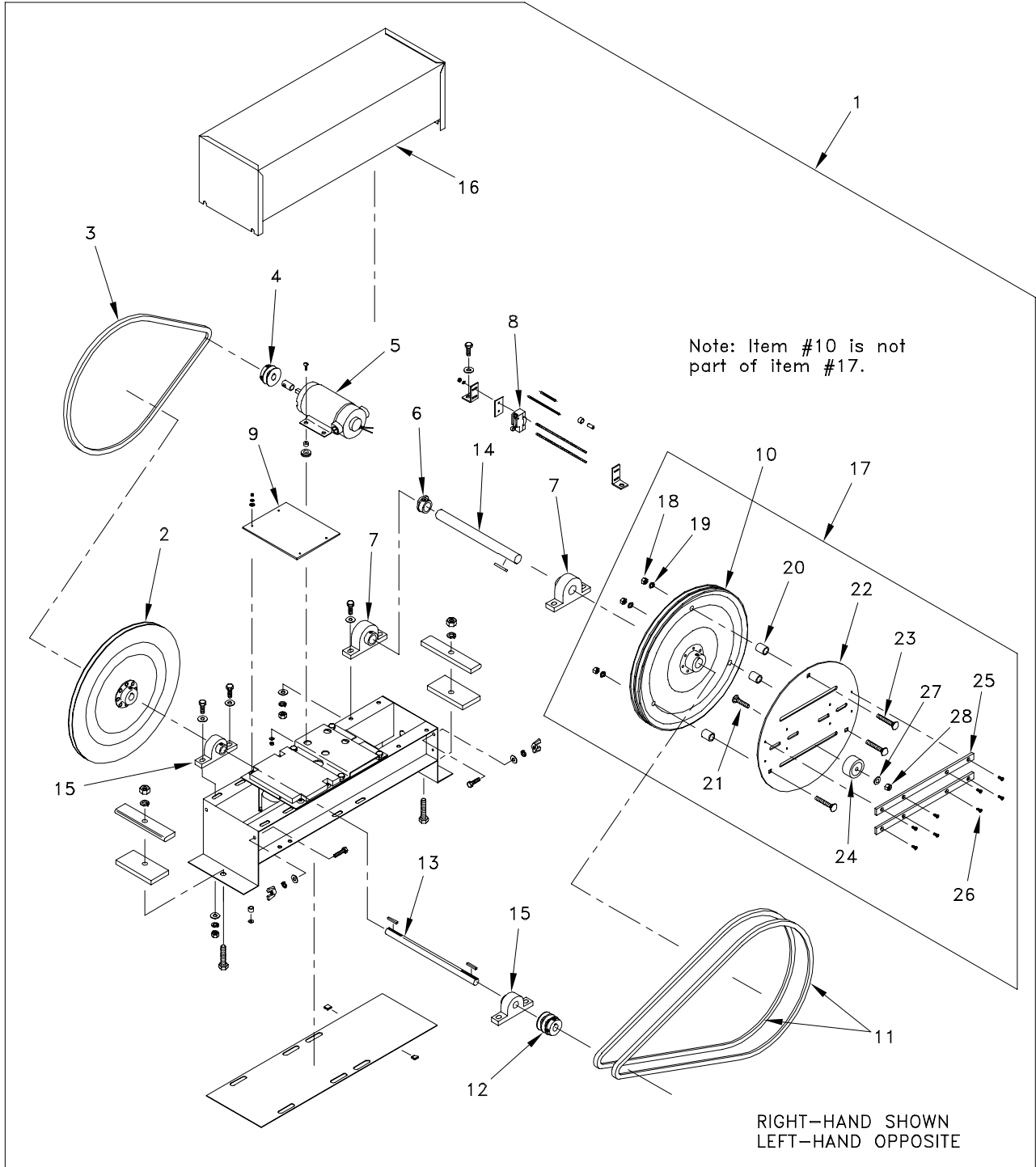

Z604-009(7/96)

Replacement Parts

GAL®-to-MAC® SIDE-OPENING DOOR OPERATOR

KEY	MKOPART	PARTNAME	REMARK
1	P-22330-001	Door operator, PM/SSC	GAL to MAC conversion, complete assembly, RH, with Board 104 and auxiliary locking board
	P-22330-002	Door operator, PM/SSC	GAL to MAC conversion, complete assembly, LH, with Board 104 and auxiliary locking board
2	19502-029	Sheave, single	15-1/4 in. diameter
3	19501-021	Belt	4L 550 Frac hp V-type
4	19502-031	Sheave, single	1.7 in. pitch for reduction
5	101849	Motor, permanent magnet	1140 RPM, 24 VDC
6	25078	Cam, door operator	7 required
7	38351	Pillow block	1 in. bore
8	100165	Switch, micro	For PMSSC door operators
9	P-22319	Door control, STD Canada	Board 104 with auxiliary locking board. Make sure top jumper trace is cut. Refer to section: Cutting top circuit trace on Door Board 104.
10	19502-028	Sheave, double	15-1/4 in. diameter
11	19501-022	Belt	4L 680 Frac hp V-type
12	19502-030	Sheave, double	1.7 in.
13	25076	Shaft	3/4 in. x 12.5 in. for reduction
14	25077	Shaft	Door operator camshaft
15	19500-032	Pillow block	3/4 in. dia. bore
16	P-24186	Cover, door operator	
17	P-22394	Adapter plate assembly	GAL to MAC conversion
18	48873-003	Nut, hex	3/8-16, G2, plated
19	48731-003	Washer, lock, spring	3/8
20	101761	Spacer	Drive sheave
21	49476-005	Bolt, Carriage	3/8-16, 1-3/4 inches long, STND, CLS 2A
22	101843	Plate, Door operator	GAL to MAC conversion
23	49476-008	Bolt, Carriage	3/8-16, L = 2-1/2 inches, STND, CLS 2A
24	101845	Roller, Door operator	GAL to MAC conversion
25	101844	Bar, Door operator	GAL to MAC conversion
26	101972-005	Screw, Flat, socket-head	No. 10-32, L= 1/2 inch
27	100052	Washer	13/32 in. ID x 3/4 in. OD x .089
28	50827-001	Nut, hex lock	3/8-16, with NYN
NS	28600	Transformer	converts 208VAC to 110VAC, used sometimes to reduce voltage going to GAL-to-MAC door operator



Replacement Parts

GAL[®]-to-MAC[®] CENTER-OPENING DOOR OPERATOR

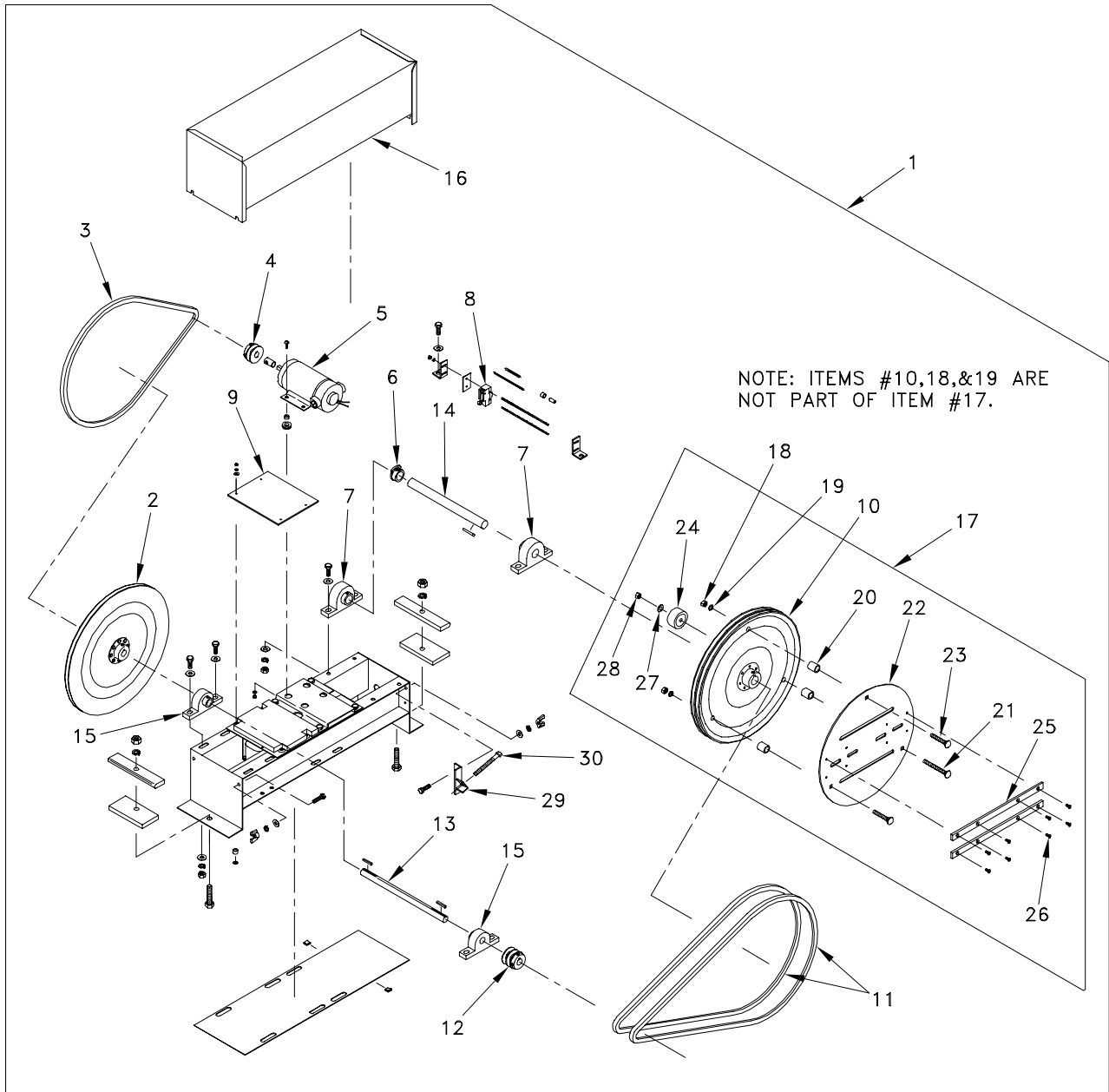

Z604-025(6/96)

Right-hand center opening door operator

Replacement Parts

GAL®-to-MAC® CENTER-OPENING DOOR OPERATOR

KEY	MKOPART	PARTNAME	REMARK
1	P-22456-001	Door operator, PM/SSC	GAL-to-MAC conversion, complete assembly, RH, center-opening, with Board 104 and auxiliary locking board
	P-22456-002	Door operator, PM/SSC	GAL-to-MAC conversion, complete assembly, LH, center-opening, with Board 104 and auxiliary locking board
2	19502-029	Sheave, single	15-1/4 in. diameter
3	19501-021	Belt	4L 550 Frac hp V-type
4	19502-031	Sheave, single	1.7 in. pitch for reduction
5	101849	Motor, permanent magnet	1140 RPM, 24 VDC
6	25078	Cam, door operator	7 required
7	38351	Pillow block	1 in. bore
8	100165	Switch, micro	For PMSSC door operators
9	P-22319	Door control, STD Canada	Board 104 with auxiliary locking board. Make sure top jumper trace is cut. Refer to section: Cutting top circuit trace on Door Board 104.
10	19502-028	Sheave, double	15-1/4 in. diameter
11	19501-022	Belt	4L 680 Frac hp V-type
12	19502-030	Sheave, double	1.7 in.
13	25076	Shaft	3/4 in. x 12.5 in. for reduction
14	25077	Shaft	Door operator camshaft
15	19500-032	Pillow block	3/4 in. dia. bore
16	P-24186	Cover, door operator	
17	P-22457-001	Adapter plate assembly	GAL to MAC conversion; used ONLY on RH center-opening door operator
	P-22457-002	Adapter plate assembly	GAL to MAC conversion; used ONLY on LH center-opening door operator
18	48873-003	Nut, hex	3/8-16, G2, plated
19	48731-003	Washer, lock, spring	3/8
20	101761	Spacer	Drive sheave
21	49476-010	Bolt, Carriage	3/8 - 16, L = 3 inches
22	101843	Plate, Door operator	GAL to MAC conversion
23	49476-008	Bolt, Carriage	3/8-16, L = 2-1/2 inches, STND, CLS 2A
24	101845	Roller, Door operator	GAL to MAC conversion
25	101844	Bar, Door operator	GAL to MAC conversion
26	101972-005	Screw, Flat, socket-head	No. 10-32, L= 1/2 inch
27	100052	Washer	13/32 in. IDx 3/4 in. OD x.089
28	50827-001	Nut, hex lock	3/8 - 16, with NYN
29	101957-001	Bracket, angle	Used ONLY on RH center-opening door operator
	101973-001	Bracket, angle	Used ONLY on LH center-opening door operator
30	61692-012	Screw, hex head cap/G2	3/8-16, L = 4 inches; used with angle bracket 101957-001
	61692-002	Screw, HHC	3/8-16, L = 1-1/2 inches; used with angle bracket 101973-001
NS	28600	Transformer	converts 208VAC to 110VAC, used sometimes to reduce voltage going to GAL-to-MAC door operator





MOLINE ACCESSORIES COMPANY
107 18th Street; Moline, IL 61265
Phone: 309-762-6888
FAX: 309-762-7475